

Project 1: W.L. Gore Iliac Bifurcation Aneurysm Model

Final Proposal

**Chadrick Jennings
Michael Seth Mabes
Nicholas Norris
Noah Wick**



College of Engineering, Informatics,
and Applied Sciences



Spring-Fall 2019

**Project Sponsor: W.L. Gore & Associates
Faculty Advisor: Dr. Tim Becker
Sponsor: William Reilly
Instructor: David Willy**

DISCLAIMER

This report was prepared by students as part of a university course requirement. While considerable effort has been put into the project, it is not the work of licensed engineers and has not undergone the extensive verification that is common in the profession. The information, data, conclusions, and content of this report should not be relied on or utilized without thorough, independent testing and verification. University faculty members may have been associated with this project as advisors, sponsors, or course instructors, but as such they are not responsible for the accuracy of results or conclusions.

TABLE OF CONTENTS

Contents

DISCLAIMER	2
TABLE OF CONTENTS	3
1 BACKGROUND	6
1.1 Introduction	6
1.2 Project Description	6
1.3 Original System	7
2 REQUIREMENTS	8
2.1 Customer Requirements (CRs)	8
2.2 Engineering Requirements (ERs)	9
2.3 Testing Procedures	10
2.4 House of Quality	12
3 DESIGN SPACE RESEARCH	13
3.1 Literature Review	13
3.1.1 Chadrick Jennings	13
3.1.2 Seth Mabes	14
3.1.3 Nicholas Norris' Research	16
3.1.4 Noah Wick's Research	18
3.2 Benchmarking	19
3.2.1 System Level Benchmarking	19
3.2.1.1 Existing Design #1: Vivitro Labs Endovascular Simulator	19
3.2.1.2 Existing Design #2: Vascular Simulations Replicator Pro	20
3.2.1.3 Existing Design #3: TrandoMed Endovascular Simulation	20
3.2.2 Subsystem Level Benchmarking	21
3.2.2.1 Subsystem #1: Measure Flow Rate [9]	21
3.2.2.1.1 Existing Design #1: Adafruit Liquid Flow Meter	21
3.2.2.1.2 Existing Design #2: STEMiNC Ultrasonic Flow Sensor	21
3.2.2.1.3 Existing Design #3: Dwyer Series SFI-800 Sight Flow Indicator and Transmitter	21
3.2.2.2 Subsystem # 2: Measure Pressure [10]	22
3.2.2.1.4 Existing Design #1: AUTEX Pressure Transducer	22
3.2.2.1.5 Existing Design #2: Dwyer Series 628CR Pressure Transmitter	22
3.2.2.1.6 Existing Design #3: Barksdale Series 600 OEM Pressure Transducer	22
3.2.2.3 Subsystem #3: Circulation of Fluid	22
3.2.2.3.1 Existing Design #1: Peristaltic pump	22

3.2.2.3.2	Existing Design #2: Piston Pump	22
3.2.2.3.3	Existing Design #3: PD-1100	23
3.2.2.4	Subsystem #4: Display of Pressure and Flow Rate Using a GUI	23
3.2.2.4.1	Existing Design #1: Arduino - The microcontroller	23
3.2.2.4.2	Existing Design #2: Raspberry Pi	24
3.2.2.4.3	Existing Design #3: LabView GUI	25
3.2.2.5	Subsystem #5: Contain Device and Fluid	25
3.2.2.5.1	Existing Design #1: Vascular Simulations	25
3.2.2.5.2	Existing Design #2: Trandomed	26
3.2.2.5.3	Existing Design #3: Solidworks Model	26
3.3	Functional Decomposition	27
3.3.1	Black Box Model	27
3.3.2	Functional Model/Work-Process Diagram/Hierarchical Task Analysis	28
4	CONCEPT GENERATION	30
4.1	Full System Concepts	30
4.1.1	Full System Design #1: Fundamental system	30
4.1.2	Full System Design #2: System with Temp Control	30
4.1.3	Full System Design #3: Complete System with Temp Control, Pulsatile Pump, Realistic Fluid, and GUI	30
4.2	Subsystem Concepts	31
4.2.1	Subsystem #1: Measure Pressure	31
4.2.1.1	Design #1: Two Pressure Transducers Surrounding Aneurysm	31
4.2.1.2	Design #2: One Pressure Transducer at Aneurysm	31
4.2.1.3	Design #3: One Pressure Transducer Before Aneurysm	31
4.2.2	Subsystem #2: Materials	32
4.2.2.1	Platinum-Cure Silicone	32
4.2.2.2	Water Clear Polyurethane Elastomer	32
4.2.3	Subsystem #3: Casting Methods	32
4.2.3.1	Design #1: Aluminum	33
4.2.3.2	Design #2: Silicone	33
4.2.3.3	Design #3: Inner core	34
4.2.4	Subsystem #4: Display Pressure and Flow Rate	34
4.2.4.1	Design #1: LabView	34
4.2.4.2	Design #2: Raspberry Pi	35
4.2.4.3	Design #3: Arduino	35
4.2.5	Subsystem #5: Circulate Fluid	36

4.2.5.1	Peristaltic	36
4.2.5.2	Piston	36
4.2.5.3	Continuous Flow	37
5	DESIGN SELECTED – First Semester	38
5.1	Technical Selection Criteria	38
5.2	Rationale for Design Selection	40
5.3	Analytical Summaries	41
5.3.1	Fluid Flow Analysis	41
5.3.2	Manufacturing Analysis	42
5.3.3	CAD Model	44
5.3.4	Materials Analysis	47
5.4	Design Description	48
5.4.1	Iliac Bifurcation Aneurysm Model	48
5.4.2	Fluid Circulation System	48
5.4.3	Data Acquisition System	48
5.4.4	First Semester Prototype	48
6	Implementation Plan - First Semester	51
7	REFERENCES	56
8	APPENDICES	59
8.1	Appendix A: House of Quality	59

1 BACKGROUND

1.1 Introduction

W.L. Gore and Associates has requested that students from Northern Arizona University (NAU) design a repeatable manufacturing process to create a model of an aneurysm in the iliac bifurcation for medical device testing. The iliac bifurcation is located below the renal descending abdominal aorta in front of lumbar vertebrae 3-5 [1]. This project begins with analyzing the structure, geometry, and mechanical properties of this region. Using non-biological materials, the team will design a model of this structure with an aneurysm in the right common iliac artery. Properties of the material selected for the model will be tested, characterized, and justified. Flow rate and pressure through the model will be measured in order to show success. A repeatable manufacturing process will be developed and documented. Twelve additional models will be produced to demonstrate the feasibility of the process.

The subsequent models of the bifurcation could be used for testing new implantable medical device designs. The overall interest of the stakeholders, besides training and recruiting engineers, is to have a model that will allow for testing of devices that will in turn save lives. The prevalence of aneurysmal disease is increasing in the elderly population with roughly 150,000 new cases every year [2]. W.L. Gore has a mission with all their products, and that is that Gore products will not fail. This is especially important for their medical devices. In order to reach such a lofty goal, Gore will have to test its devices rigorously before releasing them to the public. As research continues into both aneurysmatic models of the bifurcation and Gore, it becomes apparent that we are helping to develop life-saving equipment. If an aneurysm bursts in the abdomen there is over an 80% mortality rate [2]. With this much danger associated with a burst, it is important to have a nominal model that will aid in the development of aneurysms in this area. Modeling the iliac bifurcation with an aneurysm that matches most aneurysms in this area will help the medical community come closer to preventing this kind of death. W.L. Gore and Associates have stakes in this project because they are the sponsors, this starts and ends with Gore. The team's ability to create an accurate aneurysmatic model of the iliac bifurcation will directly affect the time it will take to develop devices for that area. This in turn will expedite the creation of devices that can save a life.

1.2 Project Description

The original project description provided by the sponsor is as follows:

“Project 1 - W.L. Gore & Associates Senior Capstone Project Proposal

Spring 2019-Fall 2019

Client - William Reilly

Scope of Work: The scope of this project is to design, build, and test a replicable model of an aneurysm in the iliac bifurcation for deployments of peripheral endovascular interventional devices under simulated use conditions, using non-biologic materials.

Overall Requirements:

1. Safe per ANSI, OSHA, or other related safety standards.
2. Design system to mimic anatomical fluid flow conditions (recommended but not limited to):
 - Flow Rate
 - Pressure
3. Develop, justify, and characterize the following attributes (recommended but not limited to):
 - Aneurysm Durometer
 - Aneurysm Compliance
 - Aneurysm Length
 - Aneurysm Thickness
 - Degree of aortic vessel growth (Creep)
4. Allow Visualization of device deployment

5. Document Repeatable Manufacturing Processes

6. Desired but not required:

A Graphic User Interface (GUI) outputting the following data to the user (recommended but not limited to):

Pressure in the Aneurysm

Flow (or leak) rate from the simulated graft to the aneurysm

Volume change rate of Aneurysm

General Control of the model or Power Off or Flow Rate

Desired Engineering Majors:

Mechanical

Budget: \$3,000¹ to cover the cost of:

Documentation (reports, presentation boards, etc.)

Materials for testing and prototyping

Construction of multiple working models.

Deliverables:

Detailed literature review, project proposal, and final report, all engineering analysis, cost estimate to duplicate, bill of materials, drawing package (if applicable), software files (if applicable), detailed procedure for repeatable manufacturing, all receipts for purchase/expenses, and 12 additional functional models for testing.

Onsite Gore Presentation:

The team will be invited to visit a W.L. Gore facility and present their project to the technical community at W.L. Gore.

¹Other resources may be provided as needed/justified” [3]

1.3 Original System

This project involved the design of a completely new aneurysm model. There was no original model when this project began. Similar models exist and are shown in benchmarking; however, an average model seems to be nonexistent. This group is working to create a model that is not patient specific but a good enough representation of an aneurysm in this area to provide adequate data.

2 REQUIREMENTS

Along with the project description that the client sent the team, a list of basic requirements were presented. These basic demands were the foundation for a list of customer and engineering requirements (CRs and ERs, respectively), that was formed in order to aid in the design process. Furthermore, the CRs and ERs were compared based on relation to determine the relative and technical importance of each. The requirements were then presented to the client, who approved of them, and their relative weights and target values. This chapter describes each of the CRs and ERs, as well as describes how they relate to each other in what is known as a House of Quality (HoQ).

2.1 Customer Requirements (CRs)

Developing a list of CRs was the first of many steps in the design process. The team needed to know the basic needs from the client and, therefore, created a list based on the project description sent to them. It can be seen from the list below that all of the CRs relate to the project requirements, each falling under a specific topic. These topics are classified by each numbered item in the project description above. The complete list of Customer Requirements is listed below, each with a description and their ratings (on a 1 to 10 scale, 10 being the most important) created by the team.

1. Safe per ANSI/OSHA (10): The first project requirement listed in the description is that the model needs to be safe according to any relevant safety standard. This is because the system will need to maintain the working fluid at a given pressure, and set temperature. Thus, the team developed this CR in order to match the client's need. The team gave this a rating of ten, because they felt that even if the model functions properly, it would be an overall failure if the client can't use the device for regulatory reasons.
2. Easy to Move (3): This CR was derived from the first one. The team felt that if the overall model was too difficult to move, then it could be considered unsafe for the client. However, it only received a rating of three, because the team determined that if the device is in a location where testing would be conducted, then movement is not entirely necessary.
3. Stable Base (4): Just like the first two CRs, this one was derived from project requirement stating that the model needs to be safe to operate. The team decided that in order to operate safely, the overall design would need to be stable while operating. This CR received a rating of four, because while it provides both safety and ease while operating, it is not as important as the first two safety CRs.
4. Mimic Anatomical Flow Conditions (7): The second requirement that the client sent the team was that the model had mimic various anatomical fluid flow conditions, such as flow rate and pressure. The team decided to give this CR a rating of seven, because if the model does not have similar flow conditions, testing can still be done, but results will not be as accurate or useful for the client.
5. Match Aneurysm Mechanical Properties (8): The third requirement is very similar to the second, in that it requires matching anatomical conditions. The client wanted the team to characterize different mechanical parameters. Therefore, the team decided to develop a model that closely follows those characterizations. The team rated this CR with an eight, because they felt that if the mechanical properties are not suitable, then the device could fail.
6. Match Aneurysm Geometry (9): This CR is also derived from the third project requirement, by requiring the matching of another anatomical condition. The geometry of the model was important to the team, because it closely relates to the devices that will be tested using the designed model. The team gave this CR a rating of 9, because if the geometry is not similar to anatomical conditions, then the client would not be able to test their devices.
7. Transparent Material (6): This CR comes from the fourth project requirement given to the team.

The model needs to have a certain degree of transparency so that the client can view their devices as they're being tested. The team gave this a rating of nine, because they felt that if the client's devices could not be seen while testing, the model is a failure.

8. Replicable Manufacturing Process (9): The fifth project requirement given by the client is that the team needed to document a repeatable manufacturing process. Thus, the team created a CR that directly relates to this deliverable. This CR received a rating of nine, because the team determined that since the client may use this model for future use, they would need to be able to recreate it, and the client stressed that this was very important.
9. Displays Pressure (5): One optional deliverable that the client presented was that of a Graphic User Interface (GUI). The team decided that a GUI would be a very important factor for the model, because it would help determine if the model is functioning as it was designed and if the client's device is implanted successfully. The team gave this CR a rating of five, because the team decided it would be beneficial to the overall model, but the client did not list it as an actual need.
10. Displays Flow Rate (5): Similar to the CR above, this CR was one that the team decided would enhance the overall model. For similar reasons, it received a rating of five; that is, because it was not explicitly needed by the client, but the team felt it would create a more functional model.

2.2 Engineering Requirements (ERs)

From each of the CRs listed above, the team developed several ERs. The ERs are quantifiable requirements that the team can measure, and provide a target for the specifications of the overall model. Each ER has a target value that the team extrapolated from their literature review, and a tolerance that the specification can be within. It is important to note that each target value or tolerance is subject to change as necessary based on new information found in research to come. That being said, all 22 ERs are listed below with their respective target values and tolerances in Table 1.

Table 1: Engineering Requirements with Respective Target Values and Tolerances

Engineering Requirement	Target Value	Tolerance
Mean Flow Rate in Left Iliac	94 (m/s)	± 10
Mean Flow Rate in Right Iliac	111 (m/s)	± 10
Aortic Pressure (Systolic/Diastolic)	141/68 mm Hg	$\pm 10/10$
Hardness	5 (Shore A)	± 15
Elastic Modulus	34.3 (kPa)	± 10
Wall Thickness	2 (mm)	$\pm .5$
Aneurysm Diameter	35 (mm)	± 5
Aneurysm Length	26.7 (mm)	± 3
Creep	2.9 (mm/yr)	± 1
Transparency	Yes/No	n/a
Fluid Temperature	37 ($^{\circ}$ C)	± 10
Weight of Entire System	22.68 (kg)	± 2
Total Cost	2800 (\$)	± 200

Diameter of Distal Aorta	19.37 (mm)	±9
Diameter of Left Iliac	16.5 (mm)	±8.5
Diameter of Right Iliac	16.5 (mm)	±8.5
Radius of Curvature at Right Junction	34.57 (mm)	±5
Radius of Curvature at Left Junction	50.5 (mm)	±5
Take off Angle of Right Common Iliac Artery	29 (degrees)	±5
Take off Angle of Left Common Iliac Artery	14 (degrees)	±5
Take Off Angle of Iliacs in Tangent Plane	15 (degrees)	±5

It can be seen that each ER has a relationship to at least one of the CRs. The ERs can be broken into different categories described by the CRs that they are related to. For example, the flow rates and pressures can be categorized by the third CR listed in the previous section. Likewise, the lengths, radii, diameters, and angles relate to the fifth CR. One ER that requires a special note is “See-Through Material”. For this, there is a yes/no requirement. This was established, because the team felt that a specific value for translucency would be too difficult to test, and beyond the scope of this project. The initial list of ERs guided the team in their research, determining different points of focus.

The ERs were all attributed a target value based on subsequent research. For example, the geometrical parameters were all developed from one of two sources [1] [4]. Likewise, the tolerances were set based on the various research that the team conducted. Furthermore, a majority of these tolerances were based on the device that the client will be testing with the model [5]. The team felt that this was the best way to justify the tolerances, because the model would be considered a failure if the client could not test their device with it. Also, these tolerances found on the client’s website fit within the range found in other research conducted [4]. All of the research conducted will be described in depth in the next chapter.

2.3 Testing Procedures

For each of the ERs listed above, the team needed to develop methods for testing in order to determine if their system meets all of the target values. These testing procedures are listed below.

2.3.1 Flow Rate

The flow rate of the system will be tested with the flow meter that will be used for the final design. This flow sensor will need to be calibrated, which will be done in the Thermal Fluids lab at NAU. To calibrate, the team will run a fluid constantly and measure the flow rate using a bucket and timer technique. This technique involves filling a cup with a certain amount of fluid and timing how long it takes to reach the specific volume. Once the flow rate of the fluid is known, the flow meter will be connected to the same source of fluid with the same flow rate. The team will be able to determine what analog signal the flow meter is outputting, which will allow them to understand the connection between the flow rate through the sensor and the signal that is acquired from the sensor. Once calibrated, the flow meter will accurately read the data for flow within the model.

2.3.2 Aortic Pressure

The pressure in the system will be tested similar to the way that flow rate is tested. The pressure

transducer that will be used for the model will also be used to verify that the pressure in the system matches the target value. Like the flow meter, the pressure transducer will need to be calibrated, which will also be done in the Thermal Fluids lab at NAU. The process of calibration will be similar to that of the flow meter. It will involve running known pressures through the sensor to understand the relation between signal output and pressure for the sensor. Once the pressure transducer is calibrated, it will read accurate pressure throughout the system.

2.3.3 Hardness

Hardness of the material will be tested using a shore A durometer. The durometer will be obtained from amazon or another suitable source. Material samples will be tested for hardness before the final models are manufactured. A finished aneurysm model will be tested with the durometer to verify hardness using the testing procedure outlined in ASTM D2240.

2.3.4 Elastic Modulus

Elastic Modulus of the material used for the vascular model and aneurysm will be tested using the hybrid rheometer in NAU's bioengineering device laboratory (BDL), which is managed by the team's faculty advisor, to observe viscoelastic behavior. Five samples of polyurethane will be cast in the same thickness as the model with varying quantities of softening agent. Samples one through five will contain 0%, 25%, 50%, 75%, and 100% of the maximum amount of allowable softening agent, respectively. The maximum ratio of liquid polyurethane to softening agent is 1:1. One sample will be tested at a time. A sample will be placed inside a ring containing deionized water. The sample and water will be heated to 37 degrees C before testing begins. An axial force of between 5N will be applied. Samples will undergo oscillation for one minute at frequencies of 0.1 to 10Hz in increments of 0.9 Hz. Complex, storage, and loss moduli will be plotted as a function of frequency. Data will be reviewed to observe viscous and elastic behavior for each material sample. Results will be compared to existing research on behavior of arteries to determine which sample exhibits the most realistic modulus. Compliance will be calculated as the inverse of modulus.

2.3.5 Wall Thickness

Wall thickness will be tested using a caliper. A caliper is available in the BDL.

2.3.6 Aneurysm Diameter

Aneurysm Diameter will be measured using a caliper.

2.3.7 Aneurysm Length

Aneurysm Length will be measured using a caliper.

2.3.8 Creep

Creep will be measured using the standard test procedure outlined in ASTM D2990-17.

2.3.9 Transparency

Transparency will be measured using a visual test. A guidewire will be inserted in the model and observed to see if the wire is visible through the vessel wall.

2.3.10 Fluid Temperature

Fluid temperature will be measured using a digital multimeter with temperature probe.

2.3.11 Total Weight of System

A container will be placed on a scale and the scale zeroed. All components will be placed in the container and weighed on the scale.

2.3.12 Diameter of Right and Left Iliacs

Diameter of both Iliacs will be measured using a caliper.

2.3.13 Radius of Curvature at Right and Left Junction

The radii of curvature will be measured by 3D scanning the polyurethane model. This will enable the

team to be able to verify that the measurements match the desired target values found in research.

2.3.14 Take Off Angle of Right and Left Common Iliacs

The angles will be measured with a clear protractor available at little cost to the team. To measure with the protractor, the team will take the centerlines for both iliacs and the aorta, and measure the angle that is created between them.

2.3.15 Angle of Iliacs in Common Iliac Tangent Plane

This angle will be measured the same way as the take-off angles for the right and left common iliacs.

2.4 House of Quality

The full HoQ can be seen in Appendix A. After the CRs were listed and each had their respective weight, and the ERs were listed each with their respective target values and tolerances, a House of Quality (HoQ) was formed. A HoQ places CRs and ERs in a grid system in order to compare them. For example, the column on the far right lists the CRs, while the ERs are listed on the top row. All of the space between the two make up the relationships between each CR and ER.

The HoQ was developed in order to determine which requirements were of more importance. Each ER was compared to a CR, and this relationship received either a one, three, or nine based on the importance that the team felt it had. For example, an ER that was directly derived from a CR was most likely given a nine. However, in some cases, an ER that was not derived directly from a CR could either receive a three or a one. This process helped the team through the design process by allowing the team to focus on specific requirements more so than others. For example, the requirement for flow rates would be more of a focus point than the requirement for hardness, because it has higher number of relationships to the CRs. Overall, it can be seen that the more important ERs are those related to flow and mechanical properties, and therefore, will be at the center of design considerations. After the HoQ was finished, the team began researching individual components for the overall design based, which will be the focus of the next chapter.

3 DESIGN SPACE RESEARCH

The client and the Project occupies the design spaces of electrical engineering, biomedical engineering, mechanical engineering, and computer engineering. In order to achieve the needs of the client, the four mechanical engineering students had to do extensive independent research in order to understand every aspect of the project. In the sections to follow there will be a literature review of the research that the team has done, its relevance, and what the original document was about. Following the literature review a display of current systems and subsystems will be reviewed in benchmarking, and our current understanding of the project is shown through the functional decomposition of a complete system as we know it.

3.1 Literature Review

In this project the research was split up into between the four team members in order to gather project information more efficiently. Chadrick Jennings has accepted the job of researching sensors and gathering statistics about ages that aneurysm occur, diameters, and locations. Michael Seth Mabe is researching Pumps to simulate anatomical blood flow and the manufacturing process of creating a characterized aneurysm. Nicholas Norris is dedicated to researching GUI interfaces and aneurysm geometry. Noah Wick has the pleasure of researching mechanical features of the vascular system and materials in order to determine a suitable material that can replicate an iliac bifurcation. The team's individual research will all come together to product our first iteration. The specific research is explained by each student in this section and its importance will be related to the project.

3.1.1 Chadrick Jennings

Mr. Jennings focused his technical research on statistics and sensors. The team needed to classify a specific age range to target, and acquire relevant data on the average geometry of each age range. Also, as is stated in the previous chapter, the team decided to incorporate a way of displaying various fluid flow conditions. Therefore, Chadrick researched potential possibilities for fluid flow measurements. Below are the relevant sources found for these technical topics.

- I. "In vivo estimation of the contribution of elastin and collagen to the mechanical properties in the human abdominal aorta: effect of age and sex." [6]

The first article that Mr. Jennings found related to his technical research gives information on several mechanical properties, including tensile stress. This data was very helpful in determining an appropriate age range to model after. Also, this source provided the team with other relevant information regarding the overall mechanics of the circulation through the abdominal aorta, and how they change with age.

- II. "Theory and Design for Mechanical Measurements" [7]

In order to understand fluid flow concepts, Chadrick used the textbook from his Experimental Methods class. This book lists different ways to measure flow, while also explaining the theory and concepts behind each method. This source has proved useful by guiding Mr. Jennings' research into a few different fluid flow measurements that could work for the model.

- III. "MEMS for Biomedical Applications" [8]

Determining which sensor to use for the model became a focus point for Chadrick, as this was one of the main areas for his technical research. He used this source to expand on different types of transducers that can be used. This book is full of information about the classification of sensors, and design considerations that are attributed to each. Also, there are specific details pertaining to certain specific types of sensors, and their biomedical applications. This guided Mr. Jennings towards certain sensors to research for the model.

IV. “Types of Fluid Flow Meters” [9]

Along with pressure measurements, the team decided to monitor the flow rate through the model. This presents the need to use some sort of fluid flow meter. This source that Mr. Jennings found explains the principles behind several different types of flow meters, and lists the different applications and benefits of each. This helps determine further research on specific types of flow meters for the model, as well as with further benchmarking.

V. “Pressure Transducers” [10]

Once Mr. Jennings determined which sensors to begin looking into, he decided to start with pressure sensing technologies. One of the most common forms of pressure measurement in industrial applications is a pressure transducer. This source expands on the working principles, applications, types and styles, and selection criteria of pressure transducers. Also, it has information for pricing that was useful for Chadrick’s benchmarking, which is mentioned in the next section of this chapter.

3.1.2 Seth Mabes

3.1.2.1 Pumps

I. “Blood-flow of the inferior mesenteric and internal iliac arteries among patients undergoing open surgery for abdominal aortic aneurysm.” [11]

Pumps will be used to artificially circulate fluid through the iliac bifurcation. The first journal review was used to determine average flow rates through the left and right iliac from 25 different patients. These studies were gathered from patients that were undergoing an aortic aneurysm repair. This information was used to develop target values for the QFD and will allow the team to choose a pump for simulating these flows. Pulsatile pumps will be necessary to simulate the heart's natural flow and through research there are four types of pumps that will be able to obtain the goal of pulsatile flow: piston, peristaltic, and diaphragm.

II. “Flow pumping system for physiological waveforms” [12]

Piston pumps naturally create an oscillatory flow and provide a consistent volume output per beat. “Flow pumping system for physiological waveforms” is an experimental journal that tested the piston pumps ability to match the heart's natural pulsatile flow. The journal explains the process of how this was achieved and tested. The piston pump ended up being able to recreate the heart’s natural flow better than any other pump on the market. The pump needed computer aided software in order to control the pumps speed throughout the stroke at any given point to obtain the desired flow. This will aid the group during concept generation to decide if the piston pump is a feasible device for the project.

III. “Dispensing with Piston and Peristaltic Pumps” [13]

This is a web article that compares piston style pumps against peristaltic pumps. This article states the strengths of each pump and their ability to simulate the proper flow metrics. The article continues to state that piston style pumps are more expensive and complex but offer the best performance, but require regular maintenance. Peristaltic pumps offer persistent flow rate performance but cannot achieve high pressures and will need to be custom built in order to achieve the proper volumetric flow rate. The article explains that several companies are moving to peristaltic pumps due to the maintenance free design and ease of adjustability.

IV. “Efficiency and Power Requirements of the Diaphragm-type Artificial Heart.” [14]

Diaphragm pumps are similar to piston but do not require regular maintenance because they do not depend on tight tolerances to operate. “Efficiency and Power Requirements of the Diaphragm-type Artificial Heart.” is a research journal that uses a dual bladder pump to artificially replicate the heart's ventricles. The article states that the pumps are not accurate in their volume output has references to state that the heart is also not consistent in its outflow volume. Diaphragm pumps volume output or pressure are not adjustable without exchanging parts.

These articles will all aid in concept generation and selection. The team will need to choose a pump that is cost effective for the given budget and a pump that can replicate the desired flow with ease. Having a pump replicate the anatomical flow of that area is a customer need and will need careful selection.

3.1.2.2 Casting

The iliac bifurcation material will be selected by the team through vigorous research and sleepless nights. Once the material has been selected or generated the next step of the project will be to mold a material into the specific geometry of the bifurcation with a CIAA (common Iliac Artery Aneurysm). A customer need is to develop a replicable manufacturing process for which the material is manipulated. The easiest way to achieve a anatomical replication would be to outsource to a company that specializes in UV 3d printing. This solution was discarded early on for concern of budget and not meeting the replicable manufacturing process of the device. The team decided to make molds and pour the liquid material into the two-piece mold to produce the body of the bifurcation.

V. “Sculpture Casting” [15]

This book yields a wide range of information in casting different materials. Chapter 2 is on casting with silicone rubber molds. This method has been incorporated into our concept selection for mold making. This chapter explains different mold release agents to use on the silicone for different types of materials. If the team chooses to use a silicone mold this book will be valuable for its step by step process on how to cure the mold.

Chapter 6 is titled Lost-wax casting. The project material will need to be hollow and a using a wax core is being considered for the core. This book reveals a step by step process on how pack material around a wax mold to pour a metal material to melt out the wax. Other methods explained are casting the wax from a mold and transitioning it to another mold.

Chapters 9 and 10 are about casting sands for metals and finishing the metal after casting. different sand and permanent sands will leave different textures on your material. Aluminum shrinkage can be controlled by the temperature of the sand before pouring the metal. If the team chooses to create

aluminum molds from casting this Book will offer great insight in how to make the method repeatable and consistent.

3.1.3 Nicholas Norris' Research

Nicholas, the team treasurer, was responsible for the team budget, purchases, and reimbursements; moreover, technical research was done in order to find arterial and aneurysmal geometry, multiple GUI options, and help to establish other target values along the way.

Target Values were researched by the entire team but Nicholas focused on the geometry of the vasculature and aneurysm of the iliac bifurcation along with research on GUI options for the project. Additional resources and their uses are listed last.

3.1.3.1 Aneurysm Geometry

I. “Study of Aortic- Common Iliac Bifurcation and Its Clinical Significance” [1]

This article was about a study of 25 cadavers that were used for dissection and information pertaining to the iliac bifurcation [1]. Data for the diameter of the common iliacs and diameter of the aorta were taken from this document and averaged against other data to come to target values.

II. “Infrarenal aortic aneurysm structure: Implications for transfemoral repair” [16]

This article was an analysis of 22 three dimensional scans of aneurysms within the renal arteries moving down the body and including the iliac bifurcation [16]. Dimensional correlations were shown throughout, but the strongest correlation was the diameter vs. length correlation shown below. Figure 1. showed that the length of aneurysms are roughly 1.5625 times the max diameter of the aneurysm according to the best fit line within the graph.

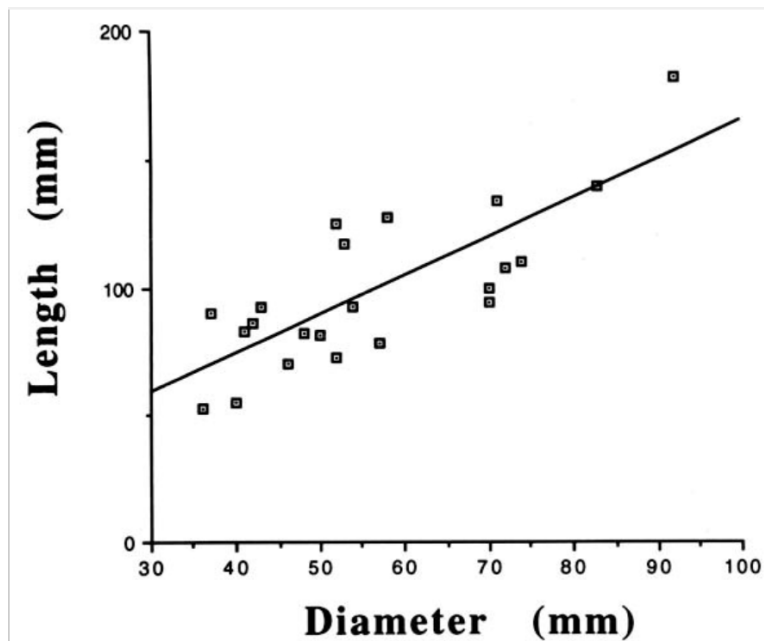

Figure 1. Length Vs. Diameter of Aneurysms with a Best Fit Line ($r = 0.79$) [16]

III. “Abdominal aortic wall thickness and compliance” [17]

This was a near comprehensive study with over 100 patients in which non-invasive methods were used to measure aortic wall thickness, describe the importance of abdominal aortic aneurysm research, and gives reason for aneurysms occurring in the age group they are seen. Elastic fibers decrease and collagen increases after the age of 50, increasing the stiffness of the aorta, thinning the vessel walls, and increasing likelihood of aneurysm [17].

IV. “Advances in determining abdominal aortic aneurysm size and growth” [2]

This article was a study of different methods of imaging that has been used to analyze aneurysm size and growth. Overall it showed that present imaging systems are more accurate and have improved surgical success [2]. This article provided significance for our project along with some size information for confirmation.

3.1.3.2 GUI Options

V. *Programming Arduino: getting started with sketches*, 2nd ed. [18]

This book is a beginners’ guide for arduino. It is an excellent resource when wiring sensors to the Raspberry Pi as it provides basic rules and tips to protect equipment. It also gave information about arduino that pushed benchmarking in a different direction.

VI. National Instruments Website “What is LabVIEW” [19]

This is a general website for nation instruments [19]. From this website, LabView data acquisition (DAQ) equipment can be seen. This website was used in order to learn more about LabView, budgeting, and specifications for comparison to other GUI options.

VII. Raspberry Pi Foundation [20]

The Raspberry Pi Foundation is an entire community that is constantly developing code, projects, and forums about Raspberry Pi and Python coding. “Getting Started with GUIs” is a page on raspberrypi.org [20] and is an excellent starting point for creating a GUI using Python.

3.1.3.3 Additional Research for Group Aid

VIII. “Reservoir Pressure Analysis of Aortic Blood Pressure – an in vivo study at five locations in humans” [21]

This article was an invasive study of 40 patients already undergoing coronary catheterization [21]. The average pressure waveforms were used to set targets for our model and pump systems.

IX. “Biaxial mechanical properties of the human thoracic and abdominal aorta, common carotid, subclavian, renal and common iliac arteries” [22]

This article pointed out the lack of a comprehensive study of large and medium sized arteries, and the mechanical properties of both diseased and healthy artery walls [22]. This article helped to confirm information found by Noah.

X. *Fox and McDonald's Introduction to Fluid Mechanics*, 9th ed. [23]

This is the fluid mechanics textbook that had been used by the group for our fluids classes. It provides formulas for pipe flow that will be used for the project as well as information about laminar and turbulent flows which will be important for analysis of arterial and aneurysmal flows respectively.

3.1.4 Noah Wick's Research

The initial focus of Noah's research was geometric anatomy of the iliac bifurcation to determine geometric parameters and target values for the model. Geometry was determined through research of the human anatomy. Tolerances for these values were based on specifications for the devices to be tested within the model. After geometry was determined, materials were researched to select the optimal material for the model. During this research, it was found that materials for the model must be compatible with mold materials should molding and casting be used for manufacturing. This resulted in some overlap between research of materials and manufacturing methods. Individual research of molding and casting helped direct the focus of materials research.

I. "Geometric anatomy of the aortic-common iliac bifurcation" [4]

This article studies the aortic-iliac bifurcation to ascertain geometric parameters of the region. The authors used tools including calipers and scales to measure and document various lengths, diameters, and angles of the aortic and iliac arteries on cadavers during autopsy. The purpose of this research was to provide useful data for further study of atherogenesis. The article provides a detailed figure of the aortic-iliac bifurcation and includes average values for geometric dimensions of this region. This information has been useful for setting target values and will be utilized to dimension the physical model of the bifurcation.

II. "Review on rubbers in medicine: Natural, silicone and polyurethane rubbers, Plastics, Rubber and Composites" [24]

Generally, describes three different elastomers and their mechanical properties, benefits and drawbacks, and medical applications. This article provided an overview of potential materials for the design to determine whether they were feasible for use with this design. This helped the team narrow down materials selection for the physical model to either polyurethane or silicone.

III. "Mechanical characterization of polyurethane elastomer for biomedical applications" [25]

This a study on mechanical properties and behavior of ether based polyurethane elastomer, specifically with reference to building mock arteries. This article documents a comprehensive study of mechanical properties of ether-based polyurethane that includes changes with varying temperature, humidity, and loading conditions. The authors reported that mechanical behavior of this material is highly dependent on temperature and humidity. The article also describes the benefits of polyurethane over silicon in medical applications. This work provided justification for materials selection and provided values for modulus of elasticity to characterize the model.

IV. Gore Medical [5]

The project goal is to produce suitable a model for testing the client's devices. To meet this goal, the model must be compatible with devices currently produced by the client. Therefore, it was necessary to determine specifications for these devices to ensure compatibility. Specifications for the device to be tested in the model were found on the Gore website, which will continue to be used as a reference throughout the project [5]. These specs were used to set target values for geometric parameters in the QFD.

V. BJB Enterprises [26]

BJB Enterprises is a source for high quality casting and mold making materials. This company is a potential source for materials that meet the project requirements. They offer several materials with a wide variety of mechanical properties to fit customer specs for many applications. Product sheets with properties of each material are available on the website. The website also contains tutorials with detailed step-by-step instructions on how to make molds and cast objects using their products. This website has been and will continue to be a valuable resource for the project whether or not materials are sourced through the company.

3.2 Benchmarking

A rough diagram of a complete system was first sketched to identify all components involved. After this top-level system concept was understood by the team, individual components were then organized into two major subsystems, fluid circulation and data acquisition. The fluid circulation subsystem contains all the required components for the project and includes the pump, pump controller, tubing with aneurysm model, and working fluid. The data acquisition subsystem contains the optional desired components to improve on the basic design and includes data acquisition software, sensors, and a graphical user interface (GUI). Components of each major subsystem were identified as individual subsystems. Benchmarking of the overall system and individual subsystems was divided among the group to complete this process within time constraints. Subsystems were selected by team members based upon their interests and SOTA literature review findings. Each team member took a unique approach to benchmarking. Details and results of individual benchmarking studies are described below.

3.2.1 System Level Benchmarking

A web search was performed to locate existing products with potential for complete system benchmarking. Through trial and error, the keywords "vascular simulators" were found to return results that included suitable products for complete system benchmarking. Three systems were found that contain all the necessary components for the project. Each of these three complete systems are listed and described in detail below.

3.2.1.1 Existing Design #1: *Vitro Labs Endovascular Simulator*

The first complete system benchmarked was the Vitro Labs Endovascular simulator (figure 1.). This system contains all the necessary components for the project. A vascular model, pulsatile pump, pump head with valves to produce circulatory flow, pump controller, tray with anatomical model, compliance assembly, heating system, and a data acquisition system that measures pressure and flow at any point in the system are all included (figure 1.). The system can be setup in multiple configurations on a bench or cart. This product has the ideal layout for our model. The open tray that contains the vascular model will provide a good reference by which to begin designing a secure frame for our model (figure 2.). The catheter insertion port is being studied by our team to understand how to design a leak-resistant insertion

port. The pump can be purchased separately, but exceeds the budget for this project.

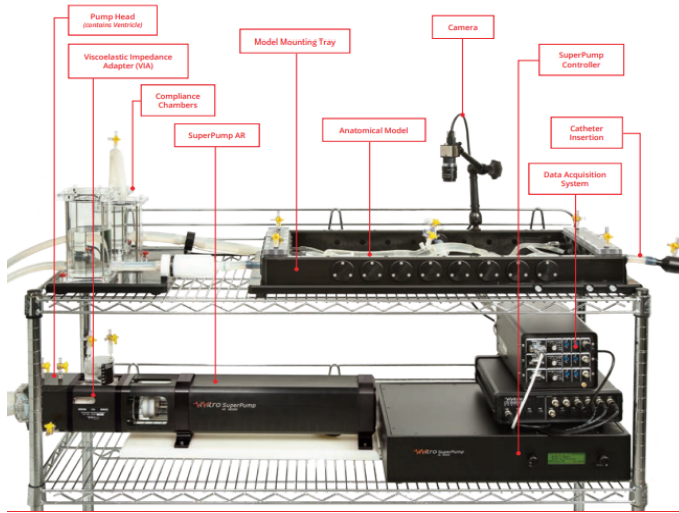

Figure 1. Vivitro Labs Complete System [27]

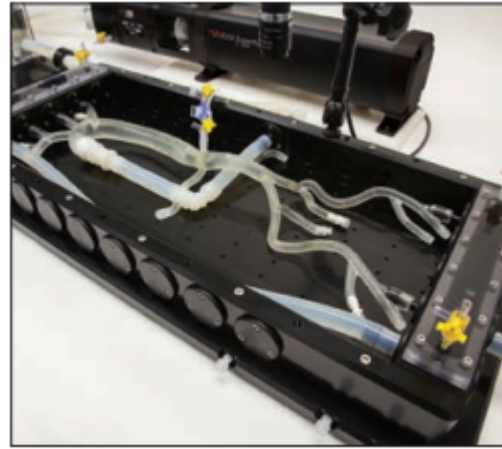

Figure 2. Vivitro Labs Vascular Model [27]

3.2.1.2 Existing Design #2: Vascular Simulations Replicator Pro

The Vascular Simulations Replicator Pro is a second complete system that meets all project requirements (figure 3.). It also includes a functioning aortic valve, which is beyond the scope of the project. In addition to providing all the necessary components shown in figure 3., the “Reflex” silicone anatomical model included with this system matches the physiological range of compliance. The system also includes multiple catheter entry ports shown in (fig 4). This design will also be studied by the team to determine how to design leak proof insertion ports and incorporate multiple ports.

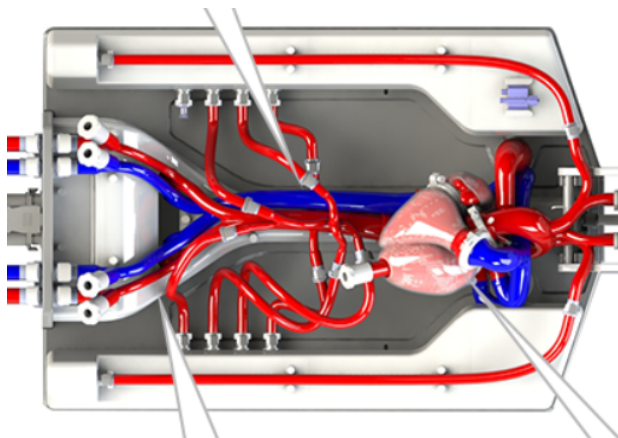

Figure 3. Silicon vasculature [28]



Figure 4. Multiple insertion ports [28]

3.2.1.3 Existing Design #3: TrandoMed Endovascular Simulation

The TrandoMed endovascular simulation is a complete system manufactured in Zhejiang, China (fig 6). Vessels in this system are composed of a proprietary silicone blend and are reconstructed from actual CT scan or MRI data (fig 5). This system is also designed for medical device deployment training using catheters or guidewire. It contains an adjustable pump system capable of reproducing physiological conditions including blood pressure, temperature, and flow rate. Four complete vessel systems or custom ordered systems are available. This product inspired the team to potentially seek MRI images for

reference.

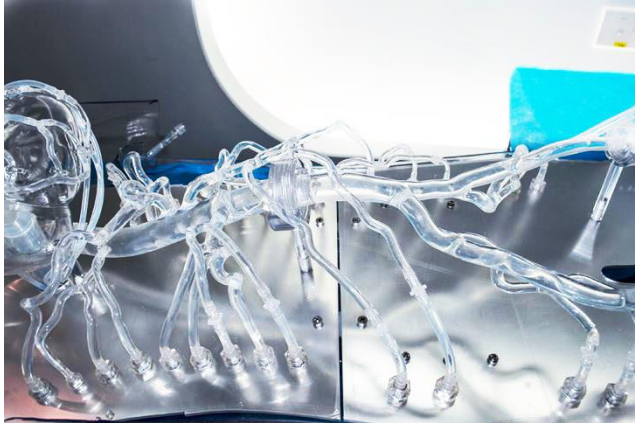

Figure 5. TrandoMed Vascular Model [29]

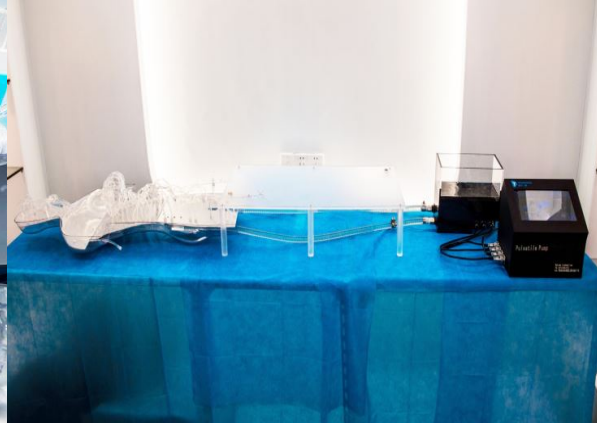

Figure 6. TrandoMed Complete system [29]

3.2.2 Subsystem Level Benchmarking

Subsystems were divided among the group in accordance to the literature review done by that group member. Chadrick's research focused on sensors and so he benchmarked sensors. This was the same for all members: Nicholas benchmarked GUI options, Seth benchmarked pumps, and Noah benchmarked materials. Casting methods was researched by Seth but no benchmarking is on these methods as the materials will sway the casting method one way or the other.

3.2.2.1 Subsystem #1: Measure Flow Rate [9]

It was decided by the team that the model should have a fluid flow condition monitoring system that would be used to display pressure and flow rate within the model. There are many different types of sensors on the market that are used to measure these values, so the team decided to benchmark with existing designs in order to aid in the concept generation and selection process. The sensor benchmarking is based on flow meters (the first three existing designs), and pressure transducers (the following subsystem). Based on this benchmarking, the team will decide which sensors will be best to use for their initial concept. Below, these benchmarks are described in detail.

3.2.2.1.1 Existing Design #1: Adafruit Liquid Flow Meter

This first design is a flow meter that can be used with liquids. It is a pinwheel flow meter, meaning that it allows the liquid to flow over a turbine, measuring the rotational speed, which can be converted to the linear speed of the fluid. This linear speed would be used to determine flow rate. This design requires careful calibration, and would not provide very accurate results. However, the cost is desirable, and it would work as a basic flow measurement device. It has threads for connection at the inlet and outlet, which could be used to attach to the model. It has a maximum water pressure of two MPa, which is well in the range that the model will be in.

3.2.2.1.2 Existing Design #2: STEMiNC Ultrasonic Flow Sensor

This flow sensor uses ultrasound technologies in order to measure the velocity of a moving fluid. It provides a much larger accuracy than the pinwheel turbine, as long as it is calibrated and configured correctly. The price is also comparable to that of the previous design, however, the team would need to buy two sensors in order to operate the system.

3.2.2.1.3 Existing Design #3: Dwyer Series SFI-800 Sight Flow Indicator and Transmitter

This design is another pinwheel flow meter. It has very similar specifications to that of the first design mentioned above. This model has a much better accuracy, but has a significantly higher price. It can operate within the specifications of fluid flow that the team is trying to achieve, including temperature

and pressure.

3.2.2.2 Subsystem # 2: Measure Pressure [10]

3.2.2.1.4 Existing Design #1: AUTEX Pressure Transducer

The next step in sensor benchmarking was to benchmark with different pressure sensing technologies. This first design is a pressure transducer made with a stainless steel body, and is compatible with water. It can operate with pressures up to 150 psi, which is well above the expected pressure for the model. It can also operate at the expected temperature for the model. This transducer has a very competitive price, and could be beneficial to the team and the model.

3.2.2.1.5 Existing Design #2: Dwyer Series 628CR Pressure Transmitter

This pressure sensor is very similar to the previous sensor, but it is a transmitter instead of a transducer. This means that the signal that it outputs is measured in milliamps instead of millivolts. This does not affect the usefulness, however, and can be accommodated for. This sensor has a higher price, but comes with a higher accuracy in the pressure readings. It operates within all of the fluid flow conditions that the model is expected to have, so this sensor is a viable option.

3.2.2.1.6 Existing Design #3: Barksdale Series 600 OEM Pressure Transducer

This last pressure sensor is very similar to the second one mentioned above. It has a comparable accuracy and operates under the same conditions. However, this product was designed to withstand more cycles in a harsher environment. This increases the price significantly, which is not desirable. With the higher price and similar specifications, this transducer is not the team's first choice for a pressure sensor.

3.2.2.3 Subsystem #3: Circulation of Fluid

It was requested by the client that the team's device must match anatomical flow rates through the iliac bifurcation and the CIAA. This need will be met by choosing or developing a pulsatile pump that can produce the necessary parameters. These pumps need to be sufficient in its ability to deliver fluid (of density 1060 kg/m^3) at 111 ml/s, with a volume of 70 ml/beat, and a pressure of 141 mmHg. These parameters will be the minimum desired specifications if a pump is reviewed it will have these qualifications and its accessories will be reviewed.

3.2.2.3.1 Existing Design #1: Peristaltic pump

The first pump is a peristaltic pump called the Masterflex L/S Compact Variable-Speed Pump. As described in the name it is a variable speed pump that can load two output hoses of the same diameter and synchronize their flow. This system can load hoses into the pump so that the pump can be removed from the system without teardown. Speed control ranges from 1.6 to 239 mL/min and is adjusted by a potentiometer. The dial type adjuster does not allow for accurate flow selection and pressure regulation is dependent on the size of the chosen tubing which will also change the flow rate. The pump is able to reverse and pause direction with the flip of a switch and has a max flow toggle switch for draining and priming. This pump has a price of 915.00 USD and is designed around medical applications.

3.2.2.3.2 Existing Design #2: Piston Pump

The Vivitro Superpump is a pulsatile piston pump that is designed for artificial circulatory use. The pump has several accessories that attach to the outlet of the pump in order to simulate multiple areas of the vasculature. The pump works on a wide range of speeds (0-200 BMP), stroke lengths to change the volumetric flow rate (0-180 mL) and the pump can change its velocity wave platform. The pump controller has a digital display to accurately control the pump. If more precise pump control is necessary, the system comes with its own software where the data collected from the pump can be displayed graphically in real time. Figure 7 is data that was collected from the pump and displayed on their software, this figure is purely just to demonstrate how the software looks and does not provide usable data.

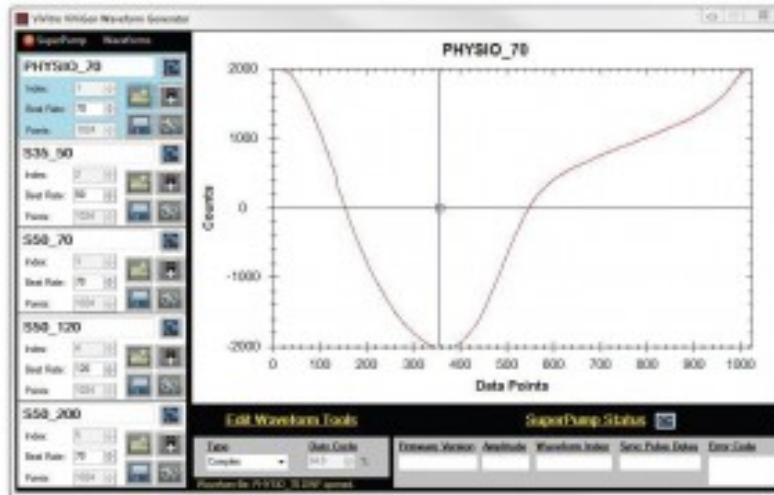

Figure 7. Data Collection from Pump Software [30]

3.2.2.3.3 Existing Design #3: PD-1100

BDC Laboratories is a company that produces testing equipment for ventricular systems. Along with their systems they sell 3 different types of piston pumps. Pumps that are specifically designed for testing artificial heart valves and pumps for testing stents and grafts. The third pump that is company sells is a fully adjustable pump to perform at a wide range of applications. This pump is called the PD-1100 and it is able to operate at: 2-240 BPM, 0-25 L/min, max stroke volume of 300 mL, max pressure of 200 mmHg, and either Sinusoidal or arbitrary waveforms. This system also comes with its own software data collection.

3.2.2.4 Subsystem #4: Display of Pressure and Flow Rate Using a GUI

This subsystem was requested but not required from the client. In order to display active changes in the aneurysm pressure and flow rate a GUI will be needed. There are many options for a GUI but Arduino, LabView, and Raspberry Pi were focused on for this project. Below is a description of the possible existing designs and equipment for each.

3.2.2.4.1 Existing Design #1: Arduino - The microcontroller

Arduino is a very powerful tool that can interface seamlessly with computers and sensors in order to achieve different desired goals. Specifically, it is for microcontroller based projects [18]. This means that achieving a true GUI can be a little more difficult in the code than other options. Arduino is by far most affordable option as LCD displays can be purchased on Amazon from three to fifty dollars [31]. Programming the microcontroller would require research and practice but could be done within the budget. LCD displays can be attached to an arduino and be programmed to display time variable data as time goes on [31]. Arduino GUIs are an option for this project still.

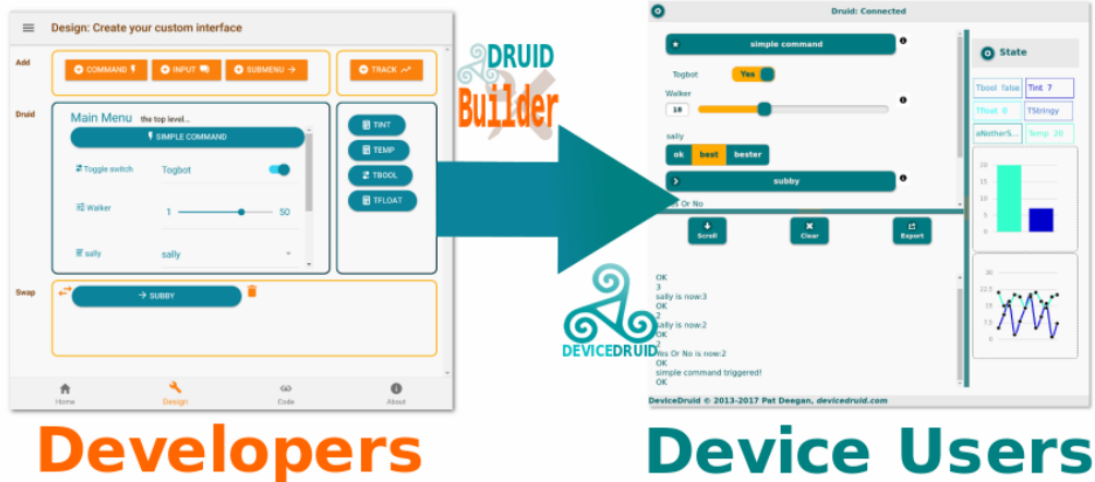

Figure 8. Example GUI created using Device Druid [32]

Arduino has the potential to display the requested data on LCD screens, but, it can also connect directly to a computer and simply transfer data to the GUI on that computer. Since the arduino community is so vast, there are other options for creating a GUI with Arduino. Online software developed by Pat Deegan can help to program the GUI for the computer and Arduino [32]. Arduino is tentatively the best option at this time because of resources like Device Druid.

3.2.2.4.2 Existing Design #2: Raspberry Pi

Raspberry Pis are considered pocket computers [20] and can be used for endless projects because of their ability to complete even the most complex of tasks. Running on Python the Raspberry Pi would be a learning experience as this language is not familiar to any group member. It is possible to run the arduino on the Raspberry Pi in order to have a take away GUI that will work for the client without need of downloading software and setting up the code on each computer.

The existing GUIs for Raspberry Pis are either a mixture of a microcontroller and Raspberry Pi or just Raspberry Pi.

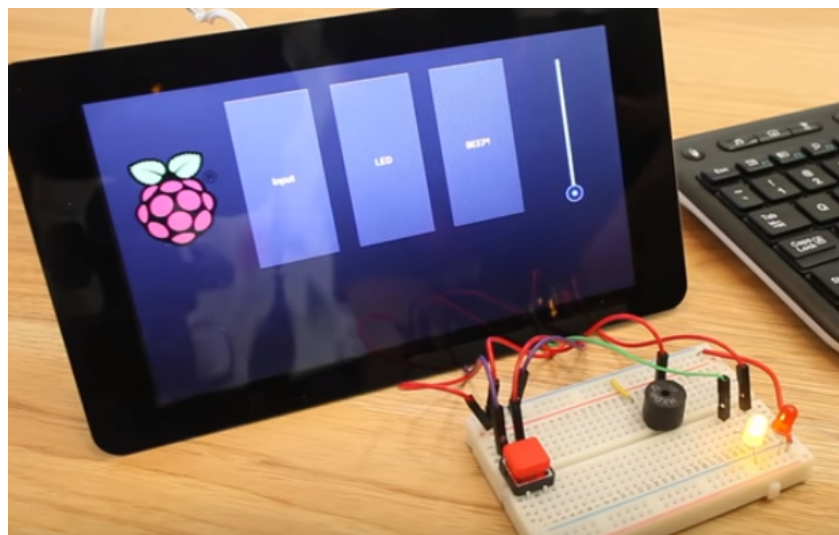

Figure 9. Example GUI using only a Raspberry Pi [20]

A Raspberry Pi would be able to create a GUI for our client. Raspberry Pi does not have a built in way to receive digital signals and would have to have an analog to digital converter to allow the pressure sensor

to work properly. Overall if the group can complete the project with an Arduino then it can also interface a Raspberry Pi to make a complete GUI that can travel with the device.

3.2.2.4.3 Existing Design #3: LabView GUI

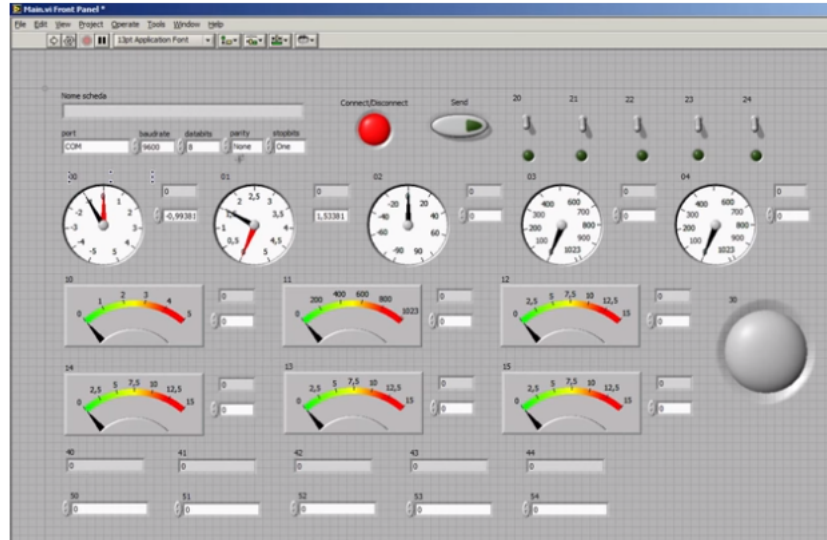

Figure 10. LabView GUI [19]

Above, Figure 10. shows a GUI created on LabView. This software by National Instruments, has been created for engineering data acquisition (DAQ) [19]. LabView is the easiest, fastest, most accurate, and most expensive option researched to create a GUI. The sensors have the highest accuracy and seamless connection to the device. The software comes with purchase of a DAQ. The software is easy to use and a simple GUI with pressure, flow rate, temperature, and volumetric change would be easy to create and navigate. This is easily the preferred method of creating a GUI; however, it is very expensive in comparison to other GUI options.

3.2.2.5 Subsystem #5: Contain Device and Fluid

This seems simple, however this is perhaps that most important condition that the team has to complete. This is because there is a large number of constraints that must be imposed on this function by request of our client. The shape must be an aneurysm in the iliac and the surrounding vasculature. This means that this subsystem has to have more than just function but also form. This subsystem must be an anatomically correct model of both a common iliac aneurysm and the surrounding vasculature.

3.2.2.5.1 Existing Design #1: Vascular Simulations

Vascular Simulations manufactures similar systems to the one we are creating. Stand-alone vascular models to contain the device and fluid are also available. These patient specific models are very accurate representations of the human anatomy. The figure below shows a large aneurysm in a similar location to the one we have been tasked with (figure 11). Vascular Simulations patient specific models are potentially not representative of the majority of the patient population. Therefore, a model will be created using nominal values from research on average dimensions of human vasculature and aneurysms in order to represent a larger patient population.

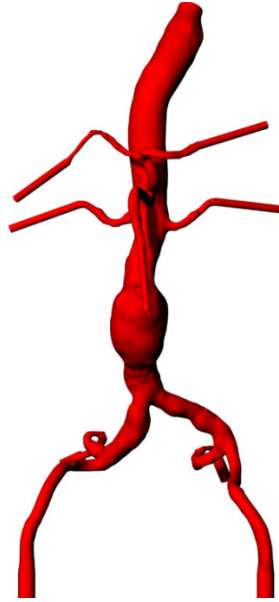

Figure 11. Patient Specific Aneurysm Model and Surrounding Vasculature [28]

3.2.2.5.2 Existing Design #2: Trandomed

Trandomed is a similar company to Vascular Simulations. They provide different aneurysms in different locations with 3D printed models of them [29]. The figure below shows one of the models produced by Trandomed. They also have patient specific prints and are out of our budget. These models will be used for inspiration as there is not a repeatable manufacturing processes to be developed with premade models.

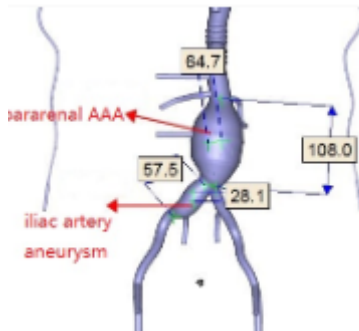

Figure 12. Patient Specific Aneurysm Model from Trandomed

This model can be used for an understanding of what the models should look like as a final design and idea.

3.2.2.5.3 Existing Design #3: Solidworks Model

Solidworks models exist on GrabCAD of numerous items. The image below is a model of an aneurysm in the aorta [33]. This was the closest model found to what we need; however, this is not anywhere near close enough to what we need for our client.

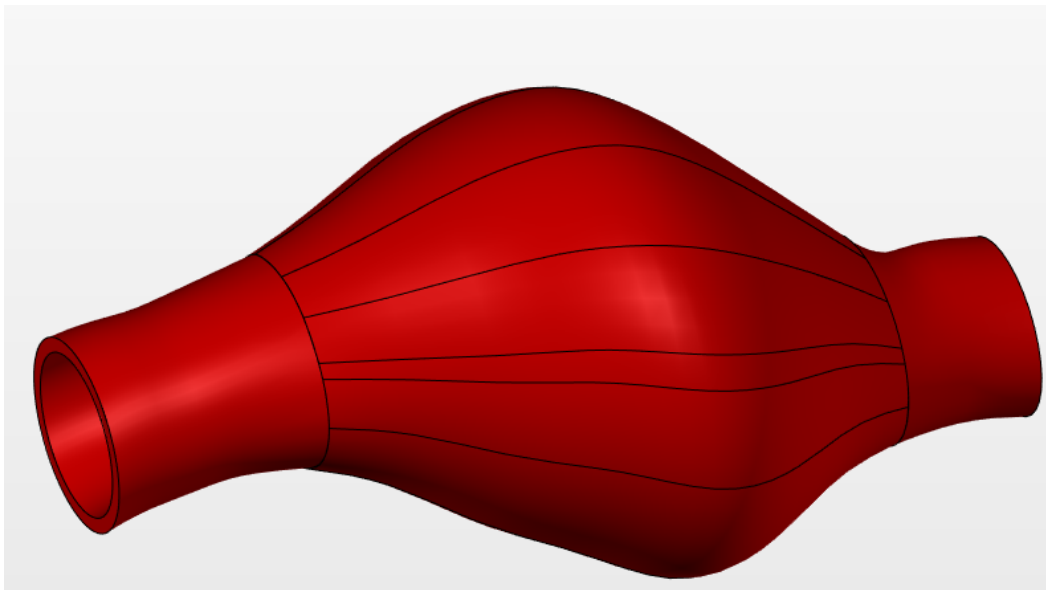

Figure 13. Aortic Aneurysm from GrabCAD [33]

This model allowed for the visualization of someone else's process in creating an aneurysm. This aided in the surface fill method that was used on the existing CAD design. For a Solidworks model to be used one had to be created by the group.

3.3 Functional Decomposition

Functional decomposition was performed to determine the overall function and sub-functions of the design. To develop a black box model, project requirements were reviewed and analyzed to identify the overall function. After a satisfactory black box model was developed, it was reviewed along with the project description to decompose the main function into sub-functions. In addition, benchmarking, which occurred concurrently, revealed components necessary for a complete system. The black box model, project requirements, and functions of components found during benchmarking were all used to define sub-functions for the functional model. Development of the black box model and functional model are described in detail below.

3.3.1 Black Box Model

The overall function for the black box model was defined as “model aneurysm” (Figure 14). Materials inputs include hand, fluid, endovascular interventional device (device), and catheter. For the model to operate, the working fluid must first be inserted by hand to create the anatomical blood flow condition. The hand then inserts a catheter which deploys the device into the model. Outputs include catheter and hand. The catheter is removed while the device and fluid remain in the model. Energy inputs include human energy and electrical energy. Human energy is necessary to insert the catheter and device. Electrical energy is necessary to power a component to circulate the fluid. Energy outputs include kinetic energy of the circulating fluid and heat energy from the pumping component. The on/off switch acts as an input signal to initiate fluid circulation. Output signals include sound, heat, and a visual signal of the device and catheter. The black box gave the team a basic understanding of the overall function of the model from which to define sub-functions.

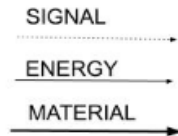
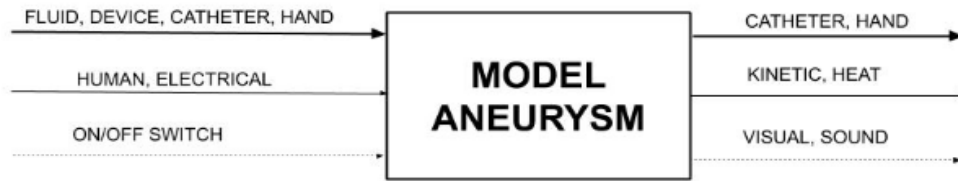

Figure 14: Black Box Model

3.3.2 Functional Model/Work-Process Diagram/Hierarchical Task Analysis

A functional model was developed to define sub-functions and identify subsystems (Figure 15). One important sub-function of the design is fluid circulation, which is necessary to mimic blood flow through the iliac bifurcation and aneurysm. Electrical energy must be imported and converted to mechanical energy to perform this action, which indicates the need for an electric pump capable of moving fluid as the human heart does. A second important sub-function is device containment, which relates to catheter insertion, device deployment, and catheter removal. The design must contain the device securely enough to prevent migration and leakage at the interface of the device and arterial wall. This indicates the geometry of the physical model must match that of the human anatomy very closely. Hardness and elasticity of the material must be realistic so that testing a new device provides a good indication of whether the device will seal properly in vivo. Further discussion of this function chain also uncovered the importance of designing an entry port that will resist leakage after the catheter and device are inserted.

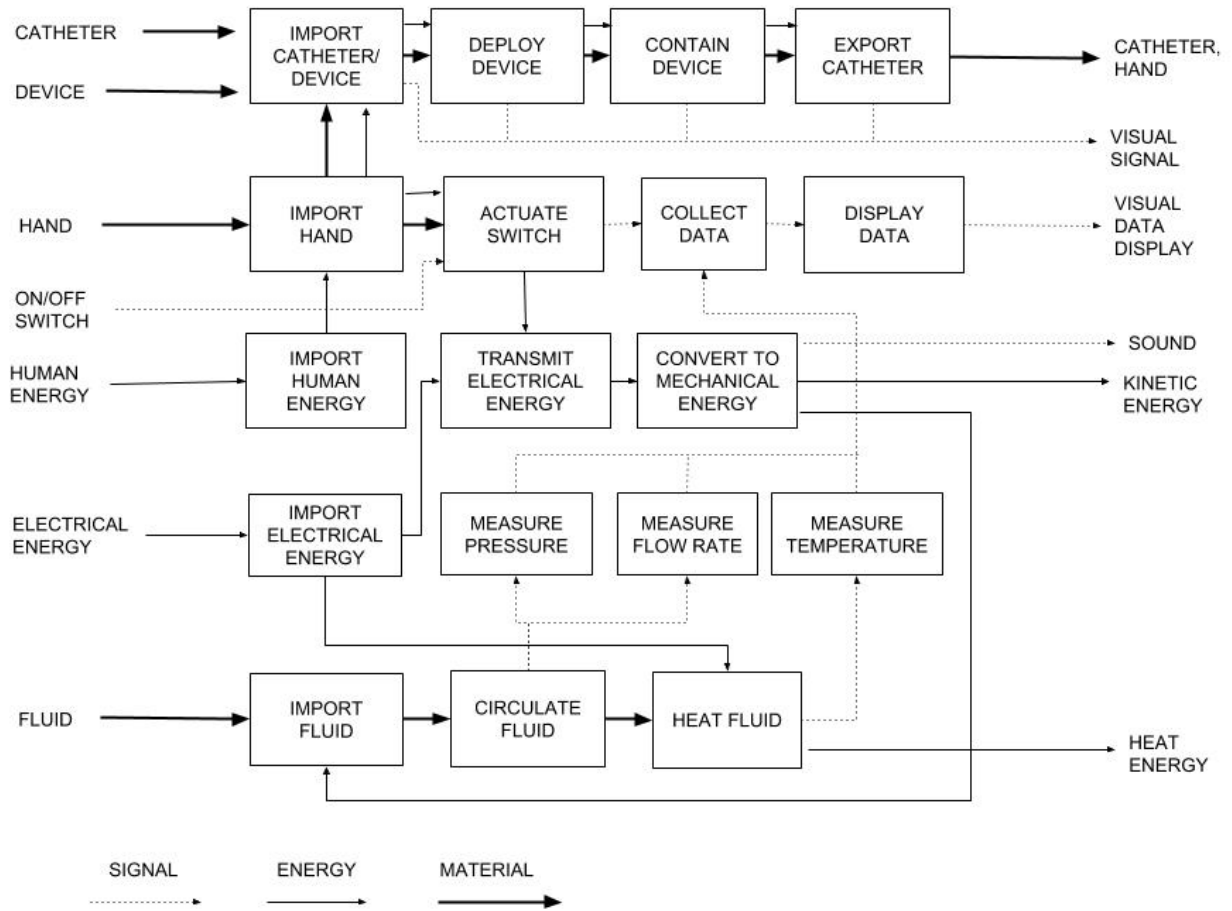

Figure 15: Functional Model

4 CONCEPT GENERATION

4.1 Full System Concepts

Three full system concepts are described below. These concepts have been generated using different combinations of subsystem concepts. Detailed descriptions of each subsystem concept with benefits and drawbacks of each follow this section.

4.1.1 Full System Design #1: Fundamental system

This design contains the following components:

- Silicone model
- Constant flow pump
- Room temperature DI water
- Pressure Gauge
- Self-Display Flow Meter

This design will be the lowest cost and most basic option to meet the design requirements. The model would be cast from 30 shore A silicone using an aluminum mold. A 60 shore A silicone mold would be created to cast a low melt wax core to shape the inside of the model. A pulsatile pump would be custom built to move the fluid. Deionized water would be used for the working fluid. No heating element would be supplied to heat the fluid.

4.1.2 Full System Design #2: System with Temp Control

This design contains these components:

- Polyurethane model
- Constant flow pump converted to produce pulsatile flow
- Temperature Control
- DI water for working fluid
- Pressure Gauge
- Self-Display Flow Meter

This design is a balance of cost and effort. It contains a model cast from 45 shore A polyurethane. The outer mold and wax core mold would both be composed of 45 shore A silicone. A constant flow pump would be adapted to produce physiological pressure and flow conditions. A heating element would be included to heat the fluid within the range of human blood temperature. Deionized water would be used for the working fluid in the system.

4.1.3 Full System Design #3: Complete System with Temp Control, Pulsatile Pump, Realistic Fluid, and GUI

This design contains the following components:

- Polyurethane model
- Off the shelf pulsatile pump
- DAQ with GUI
- Dwyer Flow Meter

- Barksdale Pressure Transducer
- Temperature Control
- Blood mimicking fluid

This complete system consists of all the required and optional components for the design. The model will be cast from polyurethane with a softening agent added to achieve a more realistic hardness. Both inner and outer molds would be created from 45 shore A silicone. The low melt temperature wax core would be used to shape the inside of the model. An off the shelf pulsatile pump would provide physiological pressure and flow conditions. Fluid with a similar viscosity and to blood would be circulated by the pump and heated to human blood temperature. Dwyer Series pressure transmitter and SFI 800 sight flow indicator and transmitter would be used with a labquest data acquisition system which will output real time data to a graphical user interface.

4.2 Subsystem Concepts

Subsystem concepts were generated in accordance to research and benchmarking so once again each piece was taken on by the group members just as before; however, Seth also handled casting methods in this section on top of pumps.

4.2.1 Subsystem #1: Measure Pressure

There are three main ways that the pressure can be measured. Each method provides an adequate pressure reading, while not significantly interfering with the model. The concepts below address those methods while incorporating a different sensor that would be used. It is important to note, though, that each configuration would only require one flow meter before the aneurysm, with no real significance in its placement, because flow rate can be assumed relatively constant throughout the modeled aorta. Both configurations are described below.

4.2.1.1 Design #1: Two Pressure Transducers Surrounding Aneurysm

One configuration in which the pressure sensors can be set is right before and right after the aneurysm in the model. This way, a pressure difference can be measured which can determine an estimated pressure inside of the aneurysm. This method would be desirable because it would maintain the complete geometry of the aneurysm. However, this configuration would require two transducers to be purchased. For this reason, it would be desired to use the most cost effective option for the pressure transducers, which would be the AUTEX Pressure Transducer. Since this is the least expensive pressure transducer, it would be acceptable to use the more expensive flow meter, which is the Dwyer Series SFI-800 Sight Flow Indicator and Transmitter.

4.2.1.2 Design #2: One Pressure Transducer at Aneurysm

Another configuration for the sensors is having only one transducer, located in the middle of the aneurysm. This setup will allow a pressure measurement to be made directly, rather than taking the difference between two points. This would create the need to create a tapping on the wall of the aneurysm, which could potentially alter the geometry and flow rate, which can skew the results. Nevertheless, this method would require only one transducer and, therefore, is more cost effective. Because of this, one of the more expensive pressure transducers and flow meters can be used. It was decided for this concept to use Dwyer Series 628CR Pressure Transmitter and the STEMiNC Ultrasonic Flow Sensor.

4.2.1.3 Design #3: One Pressure Transducer Before Aneurysm

The last way to measure the pressure is the least effective. It would involve placing just one transducer before the aneurysm, while calculating the pressure by using a fluid mechanics model of the system. This

would also be a cost effective option, because of the need for only one transducer. However, because the pressure would just be an estimate, it would not be as accurate. Therefore, it would require using the most accurate pressure transducer, which is the Barksdale Series 600 OEM Pressure Transducer. Since the pressure transducer is very expensive, it would be desired to use the cheapest flow meter, which is the Adafruit Liquid Flow Meter.

4.2.2 Subsystem #2: Materials

4.2.2.1 Platinum-Cure Silicone

Two-part room temperature thermosetting platinum cure silicone is being considered for the design due to its elastomeric properties and thermal stability. Silicon has low toxicity, antiadhesive properties, and low modulus, making it an ideal candidate for the vascular model [4]. Shore A hardness of 15-40 can be achieved with the translucent silicones being considered [26]. Although translucent, the silicon model may not be as clear as polyurethane.

4.2.2.1.1 30 Shore A Platinum Silicone

The 30 shore A translucent silicone has tensile strength of 700 psi, 400% elongation, and a tear strength of 65 pli. The mixed viscosity in the liquid state before setting is 45000 cps, and the work time is 30 min. [26] The lower viscosity will be easier to cast with than harder silicones. Although the lower tear strength and % elongation may be less desirable, this softer material may provide a better seal at the interface between the model and device. 30 Shore A hardness was also recommended by the team's faculty advisor. Thermal stability gives silicone an advantage in performing consistently under different temperature and humidity conditions.

4.2.2.1.2 40 Shore A Platinum Silicone

The 40 shore A silicone has tensile strength of 865 psi, 540% elongation, and a tear strength of 95 pli. The mixed viscosity in the liquid state before setting is 65000 cps, and the work time is 40-45 min. [26] Although the higher viscosity may be slightly more difficult to cast with than 30 shore A silicon, the longer work time may offset this. Higher tear strength and % elongation will yield a stronger model than 30 shore A silicon, but harder material may not seal as well at the interface.

4.2.2.2 Water Clear Polyurethane Elastomer

The 45 shore A polyurethane has tensile strength of 390 psi, 300% elongation, and a tear strength of 43 pli. The mixed viscosity in the liquid state before setting is 910 cps, and the work time is 20 min [26]. This low viscosity liquid may be the easiest option for pouring into a mold. This material is the most transparent of those considered and will provide the best viewing of the catheter and device during insertion and deployment. This polyurethane is compatible with platinum silicone molds, is easy to cast with and releases easily after curing [26]. Polyurethanes are also superior to silicones in abrasion and flex-fatigue life. They are highly sensitive to environmental changes, and soften significantly with increasing temperature and humidity [24]. This could be advantageous in producing a model which is rigid enough to maintain its geometry but softens under test conditions to provide realistic hardness.

4.2.3 Subsystem #3: Casting Methods

Casting the material will involve the team creating a CAD model and 3D printing that model. The 3D Print will be the foundation for several types of mold making and will need to be as precise as possible. Not only will shrinkage of the print be a critical point but the print will need to be costed and sanded to a smooth finish. Once the desired 3D print has been completed it will be time to choose a method for making the mold. Methods that have been explored and considered are aluminum casting, silicone casting, and clay packing.

4.2.3.1 Design #1: Aluminum

There are multiple ways that the team could achieve an aluminum mold. One of the team members has an aluminum foundry and has experience in casting. This method would yield a cost effective mold that would have a sandblasted looking finish across the inner surface. The mold would be aesthetically pleasing and would be an excellent prop for presentations. The strength would exceed the number of castings that this project requires and would have a long shelf life in case the project needed to be repeated in later years.

The 3D print would be made in two negative molds and then packed with petrobond sand. The sand would be removed from the mold and placed in a squared out box of more and this would leave a negative sand shell for aluminum to be poured on top of. This process would have to be repeated for each side of the mold. Silica sand would be the other option of creating this cast. Silica sand would be mixed with resin and poured into the negative and set to dry. This would create a solid mold of half of the model on a flat plane this would then have the aluminum poured over the back of the silica sand and could be reused to make multiple molds. This technique leaves the aluminum's surface much more rough compared to the petrobond [15].

Pros:

1. Strength
2. Multiple casting potential
3. Long life span
4. Impressive presentation prop
5. Cheap

Cons:

1. building time will take away from other project deliverables
2. Sandblasted texture may cause poor translucence
3. Casting shrinkage would make precise geometry difficult
4. may take several attempts

4.2.3.2 Design #2: Silicone

Silicone molding is commonly used for casting chocolate candies and other cool temperature pours. Silicone molds are able to be reused multiple times depending on the material casted. Several companies sell compliant silicon mold and cast materials. Silicone can be casted in several values for hardness ranging from shore A 15-60 [26]. Silicone has release characteristics that would allow it to release other silicones, resins, and polyurethanes. A release agent would still be used in order to extend the life of the mold. Silicone oxidizes slowly over a long period of time and this would reduce the shelf life of the mold. The 3D print would be placed in a Plexiglas box and the two-part liquid silicone mix would be slowly poured over the print, after it was degassed. The silicone would then be carefully cut away from the 3D print to yield two silicone shells. A pour hole would be cut out the top of the mold so that the material could be poured into the mold. This method would produce a smooth surface finish that would be aesthetically pleasing and would increase its translucent characteristics.

Pros:

1. Cheap compared to outsourcing a CNC mold
2. Smooth surface finish
3. Reusable

Cons:

1. Make take several attempts
2. Messy
3. Shelf life

4.2.3.3 Design #3: Inner core

The previous casting methods have all been focused on how to create the exterior of the mold. This material needs to be hollow which will involve either a second mold or some removable material for the core. The difficulty of having a removable core is the bifurcation. The bifurcation will make it so we cannot have a solid inner core. One option for a solid inner core would be to make the core like Legos. The three pieces will lock into one another and be able to be detached in order to pull them out of the material. The other consideration will be a melt-able or dissolvable material.

Solid core materials will need to be manufactured to exact geometry and be able to connect without the material leaking into the connection points. For this reason, the team will be using a melt out material. A second mold will need to be created in order to cast such a material. This cast will need to be as smooth as possible to resemble the inside of an artery. Casting wax for the core would give the team an ability to remove the core and have a smooth surface. [15]

Pros:

1. Smooth
2. Easily removable
3. Replicable process

Cons:

1. Messy
2. Material will need to withstand melt out temperature

4.2.4 Subsystem #4: Display Pressure and Flow Rate

Functional decomposition was done for the minimum requirements; moreover, a GUI was not on that list. The project team has set a goal to include a GUI. In order to display on and off positions a switch would suffice. The client requested a GUI that will display on and off, volumetric change in the aneurysm, pressure of aneurysm, and the flow rate through the model. Volumetric change in the aneurysm will be considered in later reports given that a working GUI is created to display the other three requests first. In order to fulfill this request Nicholas began research on GUI options that would be applicable to the project. Three options were found and focused on: LabView, Raspberry Pi, and Arduino.

4.2.4.1 Design #1: LabView

LabView can easily create the requested GUI. The DAQ system used in LabView is what makes the software so expensive. A sufficient DAQ for this project is shown in Figure 16 below. Using this we could make an appropriate GUI on a laptop and have the software accessible to the client.



Figure 16: USB DAQ [31]

Pros:

1. Easy to use software
2. Configure and calibrate most sensors using in software prompts
3. High level of accuracy can be established with little effort
4. Multiple device inputs are built in and ready

Cons:

1. This is the most expensive option. A single GUI with National Instruments would be 5 or more times more expensive than one from an arduino.
2. Must have a computer for working GUI.

4.2.4.2 Design #2: Raspberry Pi

A Raspberry Pi would be able to make a GUI that would be either have an LED display or a more complex graphic screen. The PI requires a wireless keyboard, mouse, HDMI screen, appropriate programming, sensors, and a few more electronic pieces to make a complete unit. This would be a carry away unit that could provide the desired GUI on the fly.

Pros:

1. Raspberry Pi foundation is a community of programmers that open source code and can help with questions on forums.
2. Affordable computer and graphical interface possibilities.
3. Complete GUI that can be taken by client.
4. Interface with microcontroller if required.

Cons:

1. Learning a new programming language python
2. Lots of start-up electronics required before programming can begin
3. Digital pins so an analog to digital converter (ADC) will be required

4.2.4.3 Design #3: Arduino

An arduino would require a computer for the GUI. The program could be uploaded via a USB to any

computer and executed to provide the requested GUI. Each sensor can be interfaced to the arduino analog pins and calibrated through the free programming supported by arduino.

Pros:

1. Most affordable option for a GUI
2. Open source community with example code and free help
3. Can be calibrated and interfaced with almost any sensor
4. Analog and digital pin receivers so ADC not required

Cons:

1. Does not have as much function as a Raspberry Pi.
2. Must be paired with a computer for GUI to work.

4.2.5 Subsystem #5: Circulate Fluid

Pumps will be key for completing our project to meet our client's needs. The pump will be used to create an anatomical pressure and flow rates of the fluid through the system. There are several pumps on the market that work with differing methods. The scope of this project is not to build a pump to achieve this flow so, the team will be looking to purchase a pump. This section will be covering the different type of pumps and not any specific brand in order to choose which style meets our criteria best.

4.2.5.1 Peristaltic

Peristaltic pump work by squeezing a flexible hose to push the fluid through the system. These pumps are usually built to deliver a set volume of fluid per beat. For the team budget it may not be feasible to purchase a peristaltic pump that would have an adjustable volume therefore, the pro and cons list will be based on a non-adjustable volume pump. These pumps are used for this type of application because of their ability to self-prime and to provide a precise amount of fluid per cycle [13].

Pros:

1. Cheap
2. Easily maintained
3. Adjustable Cycles per minute
4. Precise volume output
5. Pulsatile flow

Cons:

1. Non-Adjustable volume
2. low pressure application
3. May be built to hold one size of hose
4. Cannot control wave platform

4.2.5.2 Piston

Piston style pumps are the best at replicating the hearts anatomical flow. These pumps are expensive and require regular maintenance. This maintenance requires the system to be drained of its fluid in order to remove the pump from the system. The main reason these pumps are more commonly used is that they are adjustable for volume, pressure, and cycles. These pumps are also of few that can create a sinusoidal flow in the system to match a hearts flow [12].

Pros:

1. Adjustability
2. Anatomical replication
3. Pulsatile flow
4. Sinusoidal pressure

Cons:

1. Expensive
2. Difficult maintenance

4.2.5.3 Continuous Flow

Continuous flow pumps are usually centrifugal or axial type pumps. These pumps are starting to be used in the field of artificial medical application. These pumps are adjusted by the speed of the of the flow and pressure by the diameter increase or decrease of the output hose. These pumps can be pulsatile with computer monitoring by regulating the motors speed in a sinusoidal waveform [34]. This is not impossible to achieve for the team but may take more time than is desirable when compared to purchasing a pump that already provided a pulsatile and sinusoidal flow.

Pros:

1. Cheap
2. Reddit available
3. Meets anatomical flow is computer aided

Cons:

1. difficult to set up pulsatile flow

5 DESIGN SELECTED – First Semester

The design selected is a design that the team currently agrees will achieve the goal of the project. The overview of the project is to select a material, a pump, fluid, and manufacturing method. The project is expected to grow after these selections can be proven to function to the team specifications. The next Phase of the project the team will add a GUI and sensors to the system. These sensors will be able to prove that our system is meeting our requirement in real time.

5.1 Technical Selection Criteria

The QFD (Appendix A) lays out the projects engineering requirement and target values along with their tolerances. These target values are the results of weeks of individual research and the team's ability to gather and order the data accordingly. Each concept generation was developed with these target values in mind. If a concept could not meet these requirements the concept was discarded and a new concept was developed. The requirement will be broken down for each of the subsystem concepts and related to the customer need that they meet.

5.1.1 Sensors

The sensors that were chosen are shown below as the highest ranked designs and are able to handle the conditions that the model will be operating at. For example, the team has decided that the model will maintain a temperature of 37 °C, so the sensors must be able to withstand this temperature. Likewise, the sensors must be able to operate at a pressure between 68 and 141 mmHg, and a flow rate between 94 and 111 mL/s. Also, these sensors must be able to operate with water, or a similar fluid, as the working medium, otherwise the model will fail. Additionally, it is desired by the team that these sensors output an analog signal, and can be connected to any DAQ and GUI. Lastly, it is desired that the cost of these sensors not exceed five percent of the total budget per individual sensor.

Table 2: Decision Matrix for Flow Meters

Flow Meter Decision Matrix								
Criteria	Weight	Design 1 (Adafruit)		Design 2 (STEMiNC)		Design 3 (Dwyer)		
Cost	0.1	5	0.5	5	0.5	2	0.2	
Accuracy	0.3	2	0.6	3	0.9	5	1.5	
Max Fow Rate	0.2	3	0.6	4	0.8	5	1	
Max Pressure	0.2	3	0.6	5	1	5	1	
Installation	0.1	4	0.4	2	0.2	4	0.4	Raw Score
Compatibility	0.1	4	0.4	3	0.3	4	0.4	Weighted Score
Totals:			3.1		3.7		4.5	Weighted Total

Table 3: Decision Matrix for Pressure Transducers

Pressure Transducer Decision Matrix									
Criteria	Weight	Design 1 (Pressure Gage)		Design 2 (Autex)		Design 3 (Dwyer)		Design 4 (Barksdale)	
Cost	0.2	5	1	5	1	2	0.4	2	0.4
Max Pressure	0.1	3	0.3	5	0.5	5	0.5	5	0.5
Accuracy	0.3	2	0.6	3	0.9	4	1.2	5	1.5
Installation	0.2	4	0.8	3	0.6	4	0.8	4	0.8
Compatibility	0.2	1	0.2	4	0.8	4	0.8	4	0.8
Totals:			2.9		3.8		3.7		4

5.1.2 Materials

Materials were ranked based on availability, cost, realistic mechanical properties, transparency, and ease

of manufacturing. Each of these criteria relate directly to a customer requirement. Availability, cost, and ease of manufacturing relate to the “repeatable manufacturing process” requirement. Properties of the material selected for the model including hardness, elastic modulus, and creep relate to “match mechanical properties” requirement. Criteria were weighted based on importance rankings of customer requirements. Research was performed to identify suitable materials to meet these criteria. Polyurethane was ranked highest of the three materials.

Table 4: Decision Matrix for Material Selection

Design		Design 1		Design 2		Design 3	
Criteria	Weight	Silicone		Polyurethane		Hydrogel	
Availability	0.3	5	1.5	4	1.2	1	0.3
Cost	0.2	5	1	4	0.8	2	0.4
Properties	0.1	4	0.4	4	0.4	5	0.5
Transparency	0.2	3	0.6	5	1	4	0.8
Ease of Mfg.	0.2	4	0.8	5	1	3	0.6
Totals		21	4.3	22	4.4	15	2.6

5.1.3 GUI

GUI options were examined for ease of use and compatibility with sensors. In order to quantify ease of use Nicholas took note of each member’s familiarity with the GUI software. Sensors send signals in analog or digital; therefore, the GUI build was analyzed for both inputs. Raspberry Pi needs an ADC in order to receive analog signal and it is the least familiar programming language for the entire group, so it was at the bottom of the list for selection. Arduino is the second best as it is able to receive both analog and digital inputs but only one group member is familiar with the microcontroller. LabView was the best option as its software is familiar to half the team, it receives both kinds of input signal, and calibration of sensors is a built in function; however, the DAQ is very expensive. In order to stay within budget, the team will plan on using Arduino for the GUI.

Table 5: Decision Matrix for GUI

Design		Design 1		Design 2		Design 3	
Criteria	Weight	Arduino		LabView		Raspberry Pi	
Feasibility	0.2	3	0.6	4	0.8	2	0.4
Cost	0.3	5	1.5	2	0.6	3	0.9
Available Sensors	0.2	4	0.8	3	0.6	2	0.4
Time to Learn Language	0.1	3	0.3	4	0.4	1	0.1
Ease of use	0.2	3	0.6	5	1	3	0.6
Totals		18	3.8	18	3.4	11	2.4

5.1.4 Pumps

The client requested that the system is to be able to replicate anatomical flow conditions. These flow conditions are met through pump choice and manipulation of a pump. The engineering requirements that were created for this customer need are mean flow rates of the iliacs and the aortic pressure. There is not an engineering requirement to describe the pulsatile flow because the heart does not meet any quantifiable function. The flow and pressure targets were previously mentioned in section 3.2.2.2, 5.1.1, and can also

be found in the QDF in appendix A. Therefore, the team has chosen to use a continuous flow pump in order to replicate a static state of the heart. The figure below shows the reasoning behind the decision.

Table 6: Decision Matrix for Pump Selection

		Pumps					
Criteria	Weight	Peristaltic		Piston		Constant flow	
Availability	0.3	3	0.9	1	0.3	5	1.5
Meets CN	0.3	3	0.9	5	1.5	5	1.5
Pulsatile	0.2	3	0.6	5	1	1	0.2
Maintenance	0.1	4	0.4	3	0.3	5	0.5
Cost	0.2	3	0.6	1	0.2	5	1
Totals		16	3.4	15	3.3	21	4.7

5.2 Rationale for Design Selection

The 45 Shore A clear polyurethane will be used for the model as it had the highest score in the decision matrix. It is compatible with the silicone selected for the molds and has the lowest viscosity (910 cps in its liquid state) of any materials considered, which will make it easier to cast. It also has the highest transparency of the materials considered [26]. Polyurethane has a tear strength, abrasion, and flex fatigue life superior to silicone [25]. This material softens with increasing temperature and moisture, which should result in a good seal at the interface between the device and model [25]. A softening agent has been obtained to manipulate hardness and compliance. Samples will be cast and tested with varying amounts of softening agent before final production.

The 45 Shore A room temperature curing platinum-based silicone will be used for the molds. This material is superior for molds due to its ease of use and compatibility with the polyurethane selected for the design [26]. It will be easier to mix than other silicones due to its lower viscosity. Its 60-minute work time will allow for thorough mixing and degassing to be performed before pouring. Although the cost is slightly higher than aluminum, it will produce a model with a smoother surface. Samples of this and other silicones were obtained for testing and analysis.

Arduino is currently the preferred GUI for the system as shown in the decision matrix. This is due to the fact that the GUI can be made using DeviceDruid and the assistive software can even aid in calibration of the sensors. Although LabView is capable of interfacing and performing data collection, the cost outweighs the benefits of the DAQ. Arduino is as compatible as a LabView DAQ. It will take more work to get the GUI as user friendly as a LabView GUI, but the price of an Arduino justifies the effort. The best possible pump that the team could use is a piston style pump. The team reached out to a company to request pricing for a superior piston pump that was designed to simulate the heart's natural rhythm. This pump was priced at 25,000 USD with a 5% discount for academic purposes. The teams max budget sits at a comfortable 3,000 UDS. This pump was the absolute leader in heart simulation so, the team will continue to try to find piston style pumps in order to deliver the best performance to our client. In the event that a piston style pump cannot be found the team will resort to peristaltic pumps which are cheaper and more readily available.

Casting of the material will affect the geometry of the model and the method will need to be selected to reduce deformation and increase consistency. The bifurcations geometry is dependent on: surface roughness, wall thickness, aneurysm length, aneurysm diameter, diameter of distal aorta, diameter of left iliac, diameter of right iliac, radius of curvature of each junction, distance from bifurcation to femoral insertion point, and angles of the iliacs. These Geometric quantities will be carefully included when

producing the CAD model. The job of the casting material will be to accurately contour the 3D print without major changes to the surface of the material. These engineering requirements were developed from the customer need to match the anatomical geometry of the bifurcation and aneurysm.

Casting incorporated into concept generation to meet the client requirement for a replicable manufacturing process. If a method did not yield accuracy or consistency in each cast the concept was discarded. The engineering requirement that related to this customer need was cost. It is desired to keep the cost low which results in discarding the option of having each of the models UV 3D printed. The Decision Matrix shown below is all three designs and how they stacked against one another.

Table 7: Decision Matrix for Full System

Design		Design 1		Design 2		Design 3	
Criteria	Weight	Fundamental System		System w/ Temp. Control		System w/ full GUI	
Feasibility	0.2	4	0.8	4	0.8	3	0.6
Cost	0.2	4	0.8	3	0.6	2	0.4
Sensor Quality	0.2	2	0.4	2	0.4	5	1
Meets requirements	0.3	4	1.2	4	1.2	5	1.5
Exceeds Requirements	0.1	1	0.1	1	0.1	4	0.4
Totals		15	3.3	14	3.1	19	3.9

As you can see the group is going to attempt to exceed the client’s requirements by developing a full GUI for the minimum requirement system. To start we will finish the fundamental design so as to ensure a successful project and then more requests will be added to the design until we meet our goals.

5.3 Analytical Summaries

The Gore capstone team set out to justify initial guesses, alter methods, and learn new information about our project through analytical reports. Chadrick was tasked with a fluid flow analysis of our model in hopes that calculated information will be reflected through experimentation. Nicholas was responsible for designing a printable and anatomically correct model of the vasculature in question and the aneurysm. This was done on Solidworks with the motivation that the model would be used for the final design and testing. Seth was responsible for an analysis of the manufacturing process so that he could justify the chosen method of casting and reflect on different options. Noah was responsible for a material analysis with the motivation to identify a suitable material which would closely match mechanical properties of the human vasculature. These analytical reports brought the team closer to an anatomically correct, justified, and affordable model.

5.3.1 Fluid Flow Analysis

For this project, the client has requested that the team design and manufacture a model that mimics anatomical fluid flow conditions. Therefore, it was decided by the team that a fluid flow analysis would be completed in order to gain useful information that would benefit the overall project. The information gained in this analysis includes major and minor losses, the expected pressure drop over the entire system, and an estimate for the shear stress that the tubing is expected to experience.

In the analytical model, a pump sends water through a certain distance into a bifurcation. The fluid has to pass through a coupling where the aorta-iliac bifurcation is connected to the rest of the system. After the bifurcation, the fluid passes through an aneurysm-like fitting in the tubing. The fluid is then assumed to continue flowing infinitely, as the fluid flow characteristics are not as important after this section. The

aneurysm-like fitting consisted of a diffuser directly followed by a nozzle. However, for calculating the loss coefficient due to friction, an average was taken between the coefficients for a diffuser and a sudden expansion, as well as between a nozzle and a sudden contraction. This was done in order to get a value that was in-between those two types of fittings, because it was figured that the aneurysm would follow such a trend. All of the results gained from the analysis can be seen below in Table 8. Here, the major and minor losses for each fitting, the total loss, pressure drop, and the shear stress distribution can be seen.

Table 8: Values Found in Fluid Analysis

Value	Description	Result	Units
$h_{lm,c}$	Minor head loss for the coupling	$2.82 * 10^{-5}$	$\frac{m^2}{s^2}$
$h_{lm,b}$	Minor head loss for the bifurcation	$1.41 * 10^{-4}$	$\frac{m^2}{s^2}$
$h_{lm,ai}$	Minor head loss for the aneurysm inlet	$5.62 * 10^{-4}$	$\frac{m^2}{s^2}$
$h_{lm,ae}$	Minor head loss for the aneurysm exit	$2.91 * 10^{-4}$	$\frac{m^2}{s^2}$
$h_{IM,1}$	Major head loss between pump and coupling	$2.69 * 10^{-4}$	$\frac{m^2}{s^2}$
$h_{IM,2}$	Major head loss between coupling and bifurcation	$3.52 * 10^{-4}$	$\frac{m^2}{s^2}$
h_{IT}	Total Head Loss	0.0014	$\frac{m^2}{s^2}$
Δp	Pressure drop	2.77	Pa
τ_{rx}	Shear Stress Distribution	-0.019	Pa

The data above provides very useful information for the team, and can help make decisions for the rest of the project. Firstly, it can be seen that not much pressure drop occurs in the system. This tells the team that the losses are very minimal, and that the pressure will not be a major factor for the model. Secondly, the shear stress distribution, while just being an estimate, can show the team what kind of stresses can be expected throughout the system, which the team can use to aid in the decision of materials for the final design concept. The low stress also allows plenty of room for any additional fittings, such as sensors, that the team might want to include to the design. For future work, it is desired to analyze the entire system with all of the tubing that is expected to be used. This will help with getting a more accurate pressure drop, and will aid in selecting a suitable pump for the system.

5.3.2 Manufacturing Analysis

This Project requires the team to develop a manufacturing procedure for creating 13 CIAA models. This analysis will look at different casting possibilities and compares them to one another for cost, time, ease of manufacturing and if it will meet the needs of the client. The team spoke with the client and the client suggested to not outsource the models and to develop a replicable manufacturing process. Casting became the most feasible possibility because it will allow to team to produce consistent models when compared to other methods that this analysis will not cover. The difficulty of casting will be to produce a hollow model in which fluid will be able to flow through without leaking. The casting methods reviewed will be methods that can achieve the criteria of the project.

These methods will require the team to develop a CAD model for both the outer body and the inner core to 3D print and use as a base model to produce molds. This 3D print will need to be sanded smooth and

Painted for all the methods to be feasible. Having a CAD file enables the team to extract information like maximum (x, y, z) lengths and volumes of each of the models. These lengths will be used to construct a molding box in which a liquid will be poured over the 3D print in order to create a negative of the 3D print. Each maximum length will have 38 mm added to the total length (19mm from each side of the model). This will ensure that mold will be strong enough to hold the material that will be casted, this is a standard body size increase for casting molds. The volumes will be used to subtract the model volume from the size of the molding box volume in order to determine the amount of liquid necessary for the molds.

The team will use a platinum-based silicone for creating the molds (negatives of the print) due to its compliance with the polyurethane that we will use for the model. The box will be made of clear acrylic sheets so that the model can be seen while pouring the silicone to ensure a smooth air free pour. The volume of the outer 3D print is 49 ml and the inner is 18 ml. For ease of construction the outer models' lengths will be used to create the molding box. This will cause extra silicone to be used for the inner models' molds but will simplify the process. Using the max lengths of 130x109x55 and the outer volume the total amount of silicone needed will be 825 ml this includes a 15% increase materials for the amount that will stick to the container. Not all methods will use the inner core molds.

The methods that will be compared will be the lost wax method, solid body and solid core. The lost wax method will use both inner and outer molds. The inner mold will have hot wax casted into its core. Once cooled the wax core will be placed into the outer mold and centered using body extrusions on both models. The ends of the wax will be held by these extrusions in the outer mold and polyurethane will be casted into the outer mold revealing a polyurethane model with a wax core. The wax will be melted out with an oven and the process will repeat. The solid body method only uses the inner core model and only uses polyurethane. The same mold box will be created, and the polyurethane will be poured over the inner model and after will be removed after drying to reveal the inner cavity of a CIAA. The last method will be the same as the lost wax except a 3-piece solid core body will be developed and once the polyurethane has cured it will be detached and removed from the interior of the polyurethane. Table 9 is a Decision matrix that puts the methods against one another.

Table 9: Decision matrix for Casting Method

Methods of Manufacturing							
Criteria	Weight	lost wax		Solid body		Solid core	
client needs	0.4	5	2	2	0.8	5	2
cost	0.2	4	0.8	5	1	4	0.8
Ease	0.3	4	1.2	5	1.5	3	0.9
time	0.2	3	0.6	4	0.8	3	0.6

Totals	16	4.6	16	4.1	15	4.3
--------	----	-----	----	-----	----	-----

After evaluating each method, the lost wax method will be used for manufacturing the models. All necessary equipment and materials for this method will be priced out and listed in Table 10. This table explains how each of material will be used and states for which operation the material will be used in. The lost wax method may be more difficult than others, but it will meet the client’s needs of being consistent and providing a replicable manufacturing process. The cost and time will be close for most methods due to them needing the same materials. The Lost Wax method will be able to deliver the best product for this project and will give each team member great experience in casting. A succinct manufacturing process will be listed in Appendix D.

Table 10: Lost Wax Method Materials Sheet

Materials	Price	Amount	Quantity	Use	quantity to create molds	quantity per casting (post silicone)	quantity for 13 casts
acrylic 12x24x3/16	24.99	54 in^3	1	casting box	1 sheet	0	0
32 oz mixing containers	39.96	100 cups	1	mixing materials	6 cups	3 cups	39 cups
universal mold release	16.45	14 Fl oz	3	spray onto molds	3 Fl oz	3 Fl oz	39 Fl oz
sunco 2 gal vacuum	97.99	_	1	degas mixture	2 uses	1 use	13 uses
3D print	3	1 print	2	core for molds	2 prints	0	0
two part silicone	115	gallon	1	create 2 molds	0.5 gallons	1 use per mold	0
paraffin wax	4.99	555 ml	1	inner core	0	25 ml (reusable)	325 ml
Sulfer-free clay	13.91	5 lbs	1	create split zone	2 lb	0	0
polyurethane	115	gallon	1	cast material	0	35 ml	0.2 gallons
total cost of materials				453.28	USD		

5.3.3 CAD Model

Nicholas was responsible for the development of an anatomically correct model of a common iliac aneurysm and the surrounding vasculature. This model must be able to be 3D printed, fit averaged anatomical data found in research, and multiple thicknesses must be able to be made matching these geometries for different molds. Research was done and average values were collected (shown in Table 11).

Table 11: Averaged Values of Geometric Parameters

Parameter	Value	Unit	Reference
Diameter of Right Iliac at Bifurcation	12.71	mm	[1], [16]
Diameter of Left Iliac at Bifurcation	12.36	mm	[1], [16]
Radius of Curvature at Right Junction	34.57	mm	[1]
Radius of Curvature at Left Junction	50.5	mm	[1]
Take Off Angle of Right common iliac	29	degrees	[1]

Take Off Angle of Left common iliac	14	degrees	[1]
Diameter of Distal Aorta	21.86	mm	[1], [16]
Theta	15	degrees	[1]
Psi	10	degrees	[1]
wall thickness (Anatomical)	2.3	mm	[1], [16], [17]

These values were applied to Figures 19 and 20 in order to create a Solidworks model that would be an accurate representation of the iliac bifurcation with an aneurysm in the right common iliac.

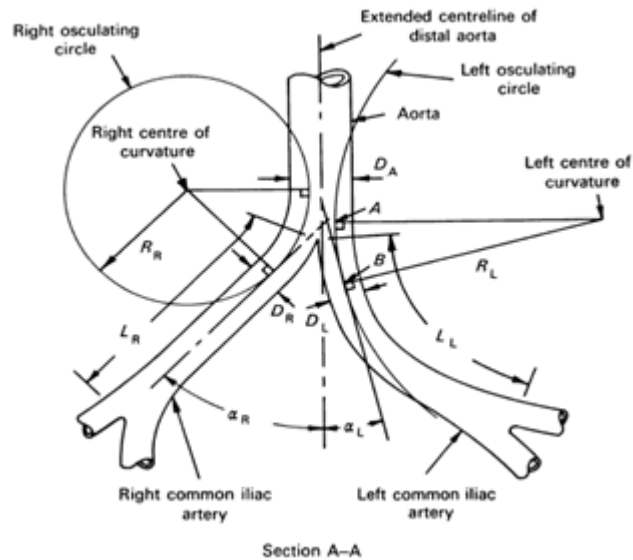

Figure 17: Geometry of the Iliac Bifurcation [1]

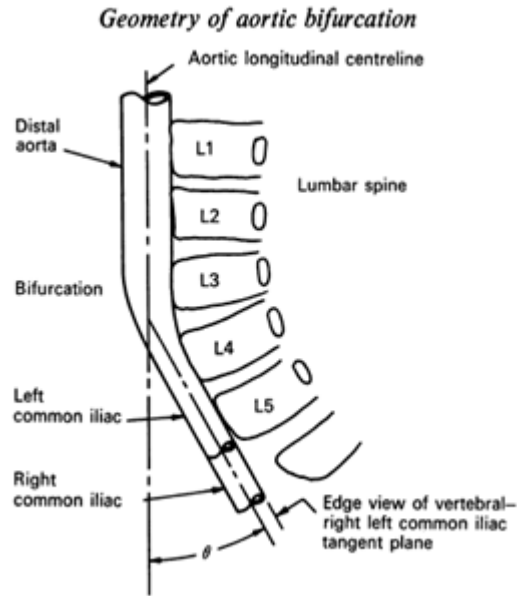

Figure 18: Geometry of the Angles for Aorta and Iliacs [1]

Numerous attempts were made to create the appropriate geometries and the final model is shown below. Multiple considerations had to be made in order to create an accurate model. The inner fluid flow is the point of interest; therefore, the point at which the common iliacs split should be rounded for accurate fluid flow. The exterior can be made to come to a point if the thickness of the polyurethane is to be more than 4mm, but the interior will be made to fit Figure 20.

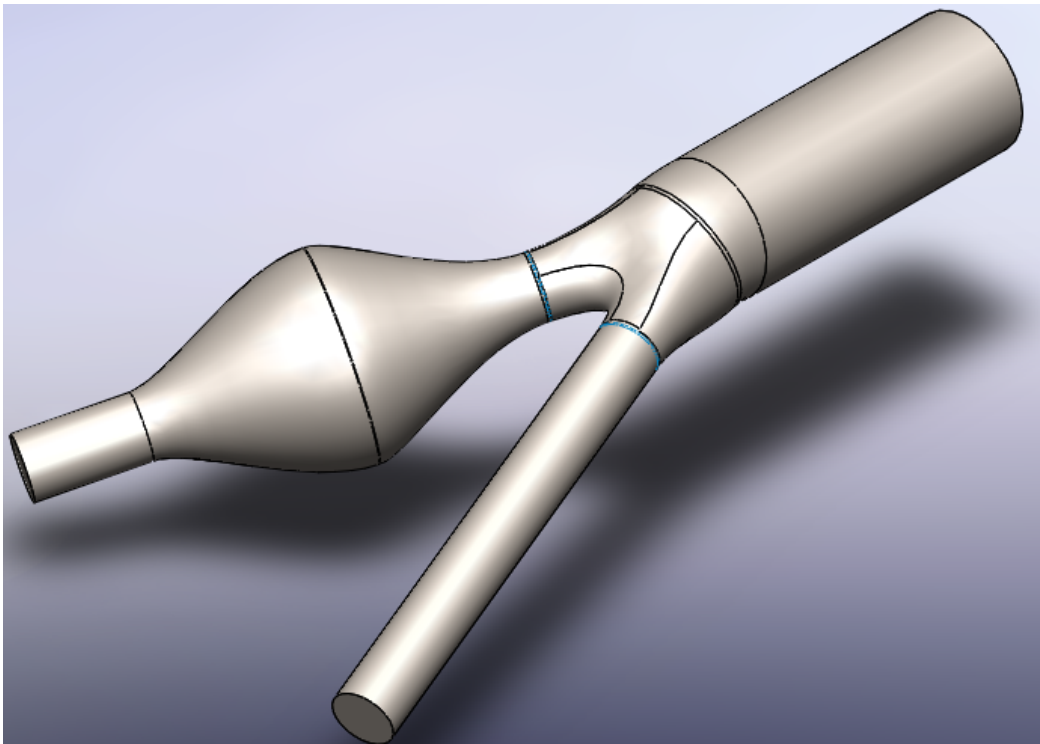

Figure 19: Solidworks Model of the Interior Wax Core for Casting Mold

Using the interior wax core model an exterior model was created to be representative of the 4mm wall thickness. These wall thicknesses can be changed; however, further testing of materials is underway to determine what thickness will create a similar compliance and hardness as real tissue.

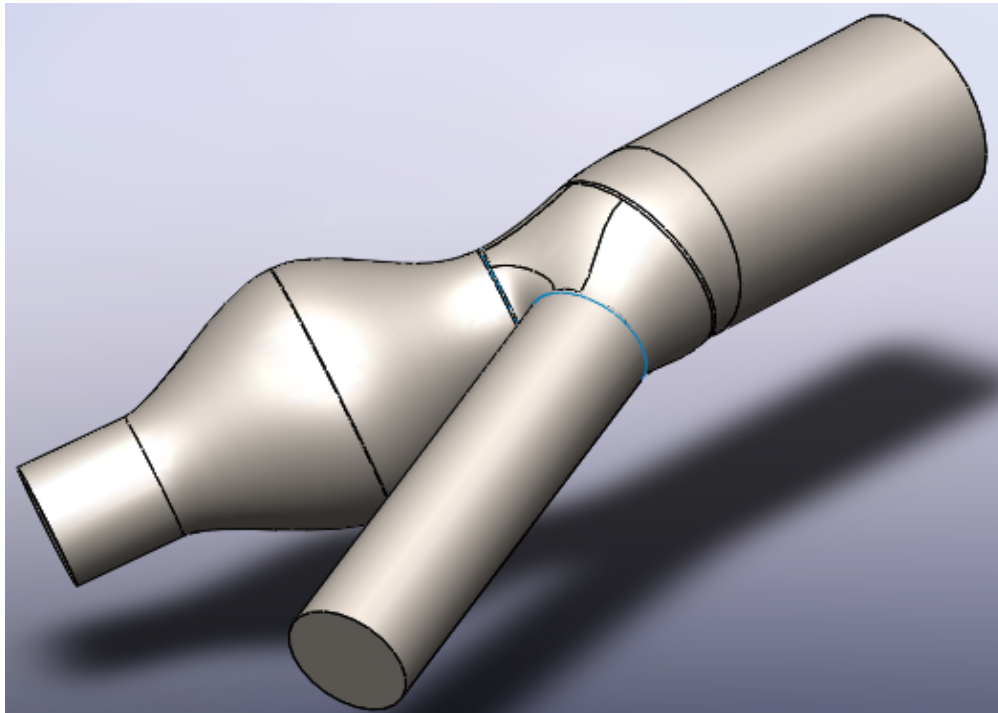

Figure 20: Solidworks Model of Exterior Mold in Accordance with a 4mm Wall Thickness

Schematics of both of these models are in the appendix. An anatomical model with accurate wall thicknesses would look something like Figure 21.

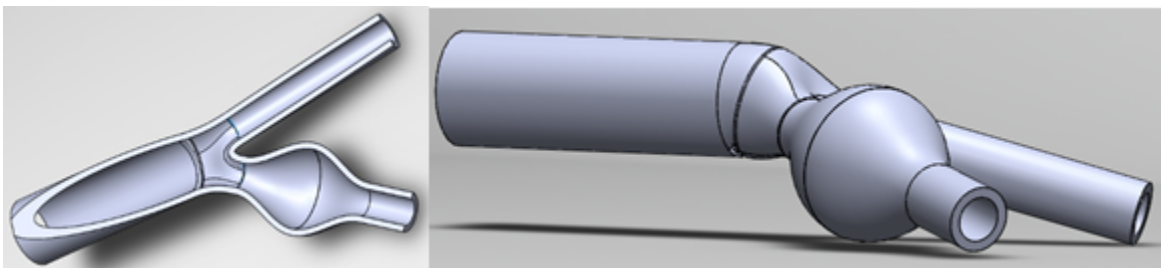

Figure 21: Solidworks Model of Anatomical Conditions

5.3.4 Materials Analysis

Since this model is being designed for testing new endovascular interventional devices, designing a model that matches hardness and compliance of human arteries as closely as possible is important to ensure tests using the model will produce relevant data for device design decisions. Since these devices are designed to bypass blood flow through the aneurysm, they must provide a good seal to exclude aneurysms and prevent leakage. How well the device will seal in vivo depends upon the degree in which it can embed in the vessel wall, which is in turn determined by the hardness of the wall. Creating a model that best represents actual hardness of the arterial wall will provide good data as to whether the device being tested will seal in vivo. Though existing research, hardness of the vessel wall was found to

be 5 shore A. This was set as the target value.

Compliance or elasticity is also highly important to this model. An endovascular device must demonstrate similar behavior to seamlessly integrate into the human blood vessel and perform well without causing problems. A device with different compliance behavior than the artery could potentially migrate, damage the vessel wall, tear, or prematurely fail in fatigue. To ensure the model is useful for device testing, it should demonstrate elasticity similar to human arteries. Because blood vessels are composed of three concentric layers with different compositions and are viscoelastic materials, they exhibit complex, time dependent behavior. Suitable materials for the model are mostly elastic and exhibit much less viscous behavior. As a result, this analysis was simplified to a single value for elastic modulus from existing research in which a simple three element model was used with a spring in parallel with a Maxwell spring-damper system. The relaxed elastic modulus of the intima, or inner vessel wall was measured at 34.3 KPa.

5.4 Design Description

5.4.1 Iliac Bifurcation Aneurysm Model

The iliac bifurcation aneurysm model will be cast from 40 shore A clear polyurethane using a silicone mold with a paraffin wax core. The wax core will also be cast from a silicone mold. The molds will be created from 3D printed parts developed from the CAD models based upon nominal dimensions of human anatomy, similar to the ones discussed in Section 5.3.2. After casting, the wax core will be melted out of the model. The model will be placed in a stable base that will allow for easier implantation of the client's devices, per the 3rd CR. This can be seen in the figure below that shows a detailed layout of the entire system.

5.4.2 Fluid Circulation System

In order to move the fluid throughout the entire design, the team developed a system to mimic anatomical flow per the CRs and ERs. This system consists of a pump, tubing, and a holding tank. The pump will serve as the "heart" of the system, creating a steady flow with constant pressure and flow rate. The tubing will serve as the system's "arteries", and will carry the fluid through the aneurysm model. The tank will hold all of the fluid that is not circulating through the tubing, and is where the pump will draw the fluid from. The tubing will have a certain length, characterized by the fluid analysis discussed in Section 5.3.1. The tank and pump will be housed beneath the aneurysm model, as seen in the figure below.

5.4.3 Data Acquisition System

Because the client desires that the design displays pressure and flow rate data, the team has created a way to measure said data, and display by means of a GUI. This satisfies the 9th and 10th CR listed in Chapter 2. The selected sensors will read the appropriate data, a data acquisition system will interpret that data, and the data will be displayed on a screen for the user to see.

5.4.4 First Semester Prototype

The first semester bifurcation aneurysm prototype (Figure 22) was manufactured using the methods described above. The geometry was developed from an early iteration of the CAD modeling process (Figure 23). This geometry is accurate aside from the internal diameters of the arteries and the sharp corner at the junction of the two common iliacs. The sharp corner increases the possibility of a tear in the model at the bifurcation. The smaller internal diameters made the wax core difficult to handle after casting. It took several trials to successfully cast and remove a wax core without it breaking. The final

models will be cast from a mold made from a later CAD model iteration which has a smooth, rounded junction at the bifurcation, more representative of the human anatomy, to reduce the possibility of a tear. The internal diameters of the arteries will be corrected to represent nominal values, which will aid in casting a wax core capable of being handled without breaking.

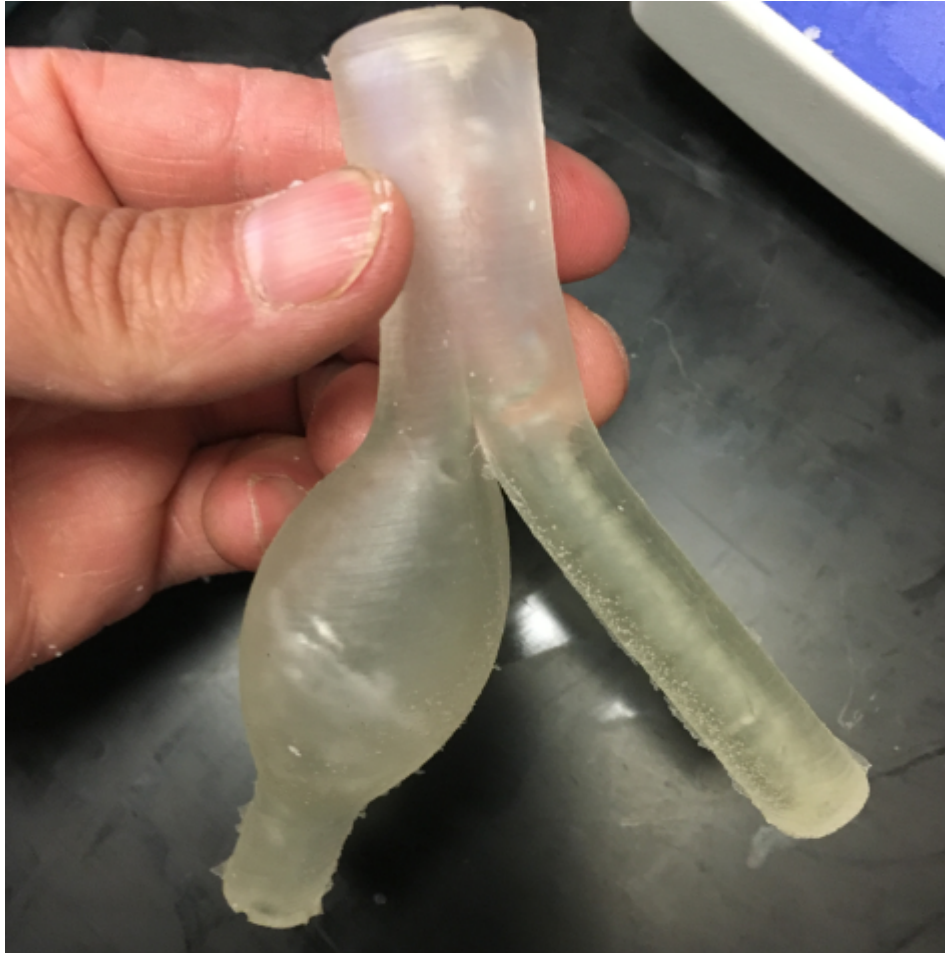

Figure 22: First semester iliac bifurcation aneurysm prototype



Figure 23: Early iteration anatomically correct CAD model

6 Implementation Plan - First Semester

As it stands, the group has a prototype model completed. This model was made in order to justify the manufacturing process chosen by the team. A full system prototype has been developed in Solidworks in order to set a goal for the coming semester. Shown below is a proof of process proving that our method of manufacturing is a successful one.



Figure 24: Prototype Iliac Bifurcation Model Proving a Successful Manufacturing Process

The model was not the final model shown in the analytical report. This model was completed early and showed some key issues that the group will be considering with more iterations of the process. The molds will be used for demonstration day. A full system prototype will be completed before the end of May. Shown below are Solidworks CAD images of the envisioned full system concept that the full system prototype will be compared to.

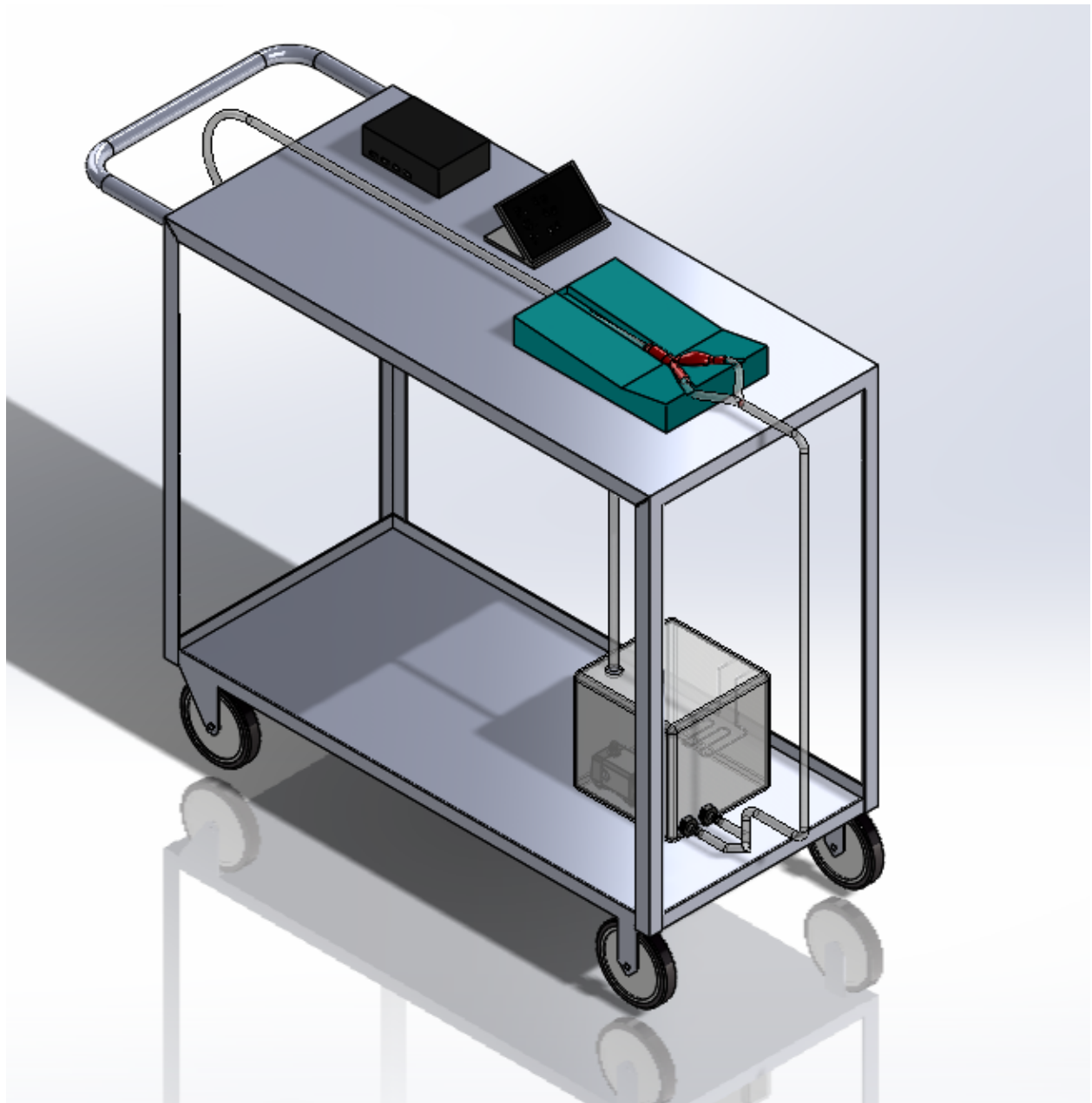

Figure 25: Final CAD Model

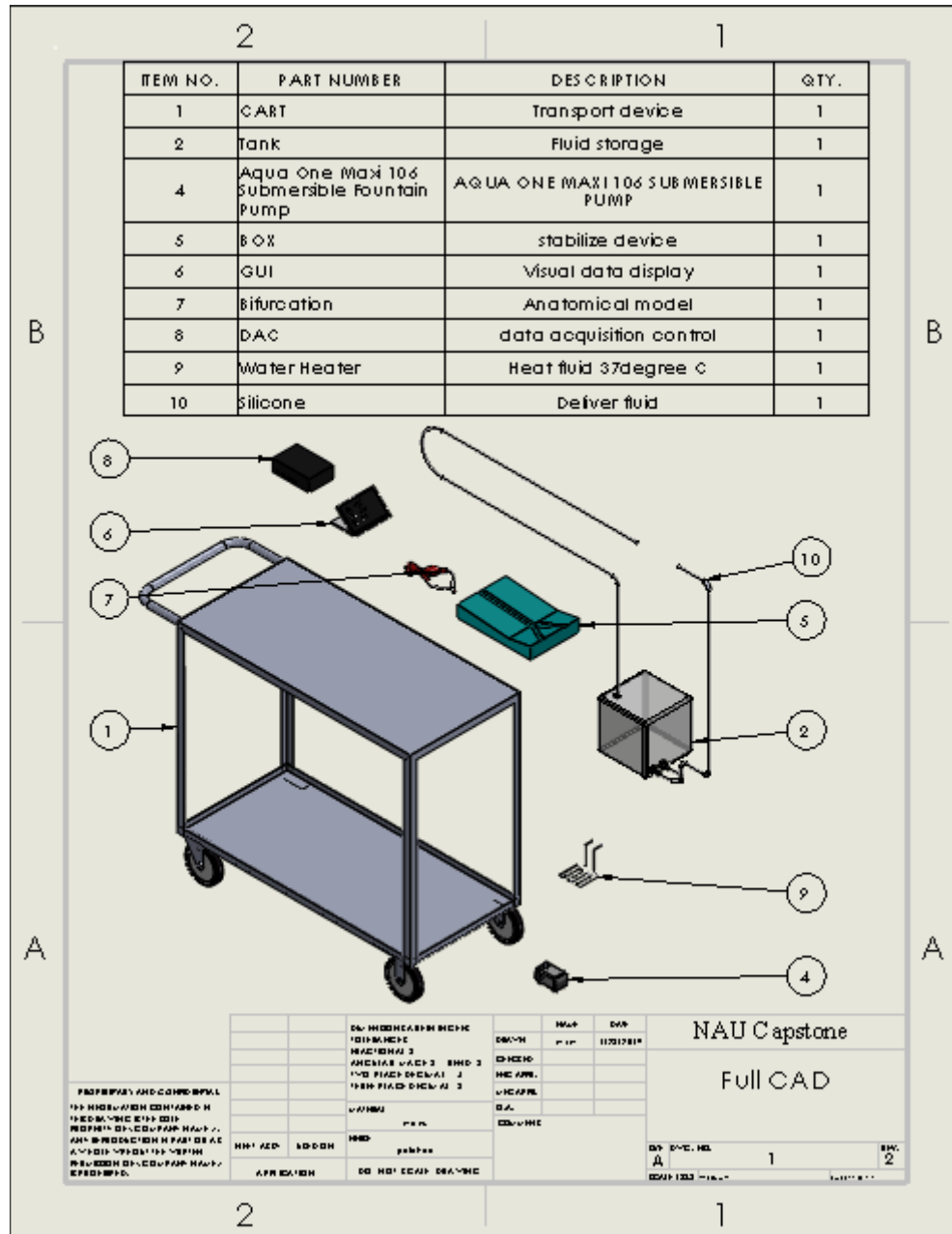

Figure 26: Exploded CAD model with atlas

A Prototyped Model without a GUI display would require the resources listed below.

Table 12: Detailed Breakdown of Resources Required for Design Implementation

Resource Needed for Design	Dollar Cost	Time Dedicated	Manufactured/ Provided By:
Little Giant 523003 P-AAA Manual Submersible Recirculating Water Pump	\$53.51	0 Hours	Little Giant

3D Printed Mount for Model	\$10.00	5 Hours	MakerLab and Team Member
80855 500-Pound Service Cart With Two Trays	\$79.99	0 Hours	Max Works
3 Gallon Stainless Steel Vacuum Degassing Chamber and 3 CFM Single Stage Pump Kit	\$169.99	0 Hours	Ablaze
Silicone Tubing	\$0.00	0 Hours	Client Provided
3D Printed Model for Mold Making	\$2.50	6 Hours	MakerLab and Team Member
Mold Making Kit MMK-1-Each	\$118.00	0 Hours	BJB Enterprises
TC-5041 A/B-Gallon Kits = 8 lbs. A, 13 oz B (3.6kg A, 0.3kg B) - Silicone for Mold Making	\$120.30	0 Hours	BJB Enterprises
Both interior and Exterior Molds	\$0.00	10 hours	Team
Microcrystalline Wax	\$13.00	0 Hours	Blended Waxes Inc.
Wax interior	\$0.00	1 Hours each	Team
WC-540 A/B-Quart Kits = 1 lb. A, 2 lbs. B (0.45kg A, 0.9kg B) - Polyurethane for Model	\$75.00	0 Hours	BJB Enterprises
Model	\$0.00	2 Hours each	Team
Nxtop 1" Flow Water Sensor Meter+Digital LCD Display	\$63.39	0 Hours	Nxtop
KC25-3# Low Pressure Gauge 3 PSI	\$27.46	0 Hours	Kodiak Controls
Access to Facility to Cleanly implement Process	\$0.00	0 Hours	Dr. Becker
Totals	\$733.14	60 Hours	

Given the final design may change and the budget includes prototyping along with extra money for possible expenses the budget (in Appendix C) will have a much higher final cost. This is only an estimate of the implementation of the simplest final designs the team has conceived in order to determine minimum requirements and costs. In the semester to come this implementation table will be a good example of what will be needed for our 13 models to be created. The new CAD model will be used to make new molds, and depending on testing, the polyurethane that will be used will be thinned to more accurately mimic anatomical properties. A schedule outlining the tasks for next semester has been created to help organize the remainder of project (Figure 27).

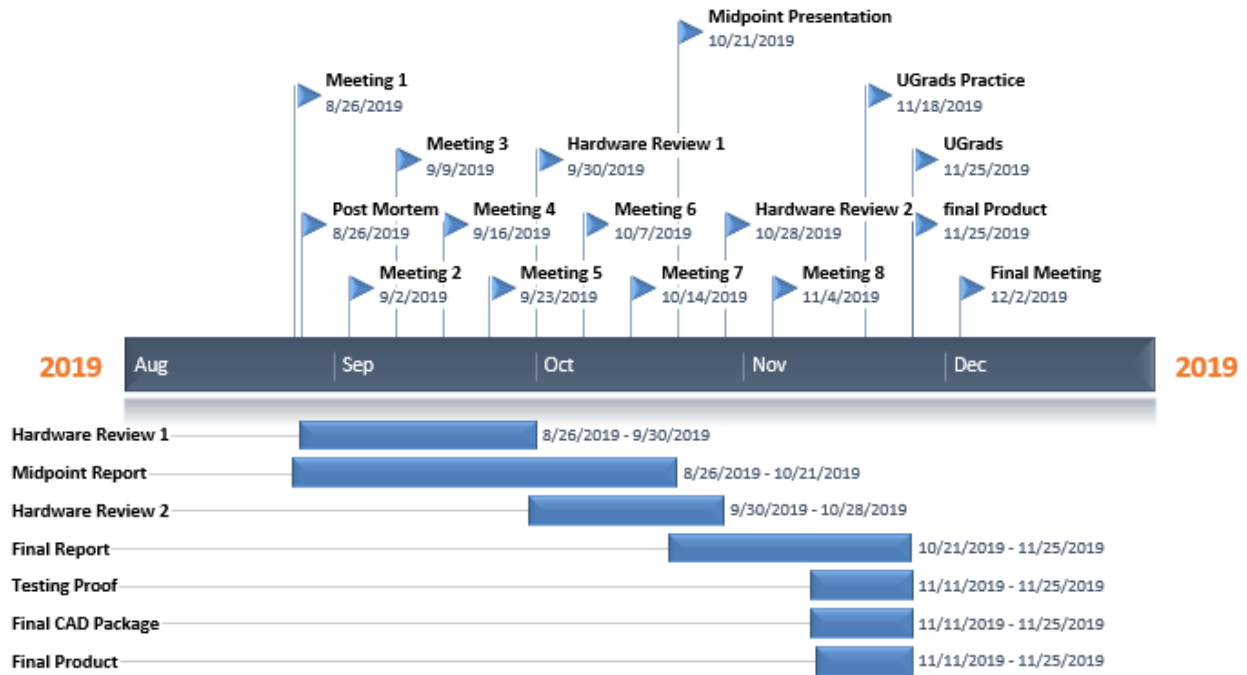

Figure 27: Next Semester Schedule

7 REFERENCES

- [1] A. Deswal, B. K. Tamang, A. Bala, “Study of Aortic- Common Iliac Bifurcation and Its Clinical Significance,” *Journal of Clinical & Diagnostic Research*, vol. 8, no. 7, July, 2014. [10.7860/JCDR/2014/8767.4559]. Available: <https://www.ncbi.nlm.nih.gov/pmc/articles/PMC4149059/>. [Accessed Feb. 25, 2019].
- [2] N. Kontopodis, Et al., “Advances in determining abdominal aortic aneurysm size and growth,” *World Journal of Radiology*, vol. 8, no. 2, February 2016. [doi: 10.4329/wjr.v8.i2.148]. Available: <https://www.ncbi.nlm.nih.gov/pmc/articles/PMC4770177/>. [Accessed Feb. 26, 2019]
- [3] W. Reilly. “Project 1 - W.L. Gore & Associates Senior Capstone Project Proposal,” Project Description (January, 2019)
- [4] P. Shah, H. Scarton, And M. Tsapogas, “Geometric anatomy of the aortic-common iliac bifurcation,” *Journal of Anatomy*, vol. 26, no.3, pp. 451-458, Aug 1978.
- [5] W. L. Gore & Associates (2019) goremedical.com [Online]. Available: <https://www.goremedical.com/products/excluder/specifications> [Accessed Mar. 3,2019]
- [6] H. Astrand, Et al., “In vivo estimation of the contribution of elastin and collagen to the mechanical properties in the human abdominal aorta: effect of age and sex,” *Journal of Applied Physiology*, January 2011. [doi: 10.1152/jappphysiol.00579.2010] Available: <https://www.physiology.org/doi/full/10.1152/jappphysiol.00579.2010>. [Accessed Feb. 28, 2019].
- [7] R. S. Figliola, D. E. Beasley, *Theory and Design for Mechanical Measurements*. Hoboken: John Wiley and Sons, Inc, 2011.
- [8] Shekhar Bhansali and Abhay Vasudev, *MEMS for biomedical applications*, Oxford : Woodhead Pub., 2012. [E-book] Available: <https://www-sciencedirect-com.libproxy.nau.edu/book/9780857091291/mems-for-biomedical-applications>. [Accessed Feb. 28, 2019].
- [9] Engineering ToolBox, *Types of Fluid Flow Meters*. 2003, [online] Available: https://www.engineeringtoolbox.com/flow-meters-d_493.html [Accessed Feb. 28, 2019].
- [10] OMEGA engineering, “What is a Pressure Transducer?,” *OMEGA engineering*, 2003 - 2019. [Online] Available: <https://www.omega.com/prodinfo/pressure-transducers.html>. [Accessed Feb. 28, 2019].
- [11] Björck and Bergqvist (2006). Blood-flow of the inferior mesenteric and internal iliac arteries among patients undergoing open surgery for abdominal aortic aneurysm. *Vasa*, [online] 35(1), pp.11-14. Available at: <https://www.ncbi.nlm.nih.gov/pubmed/16535963/>. [Accessed 3 Mar. 2019].
- [12] Tsai, W. and Savaş, Ö. (2010). Flow pumping system for physiological waveforms. *Medical & Biological Engineering & Computing*, [online] 48(2), pp.197-201. Available at: <https://www.ncbi.nlm.nih.gov/pmc/articles/PMC2807595/>. [Accessed 3 Mar. 2019].
- [13] LAMBERT, P. (2019). [online] Available at: <http://www.pharmtech.com/dispensing-biopharmaceuticals-piston-and-peristaltic-pumps> [Accessed 3 Mar. 2019].
- [14] Donovan FM Jr, e. (2019). Efficiency and power requirements of the diaphragm-type artificial heart. - PubMed - NCBI. [online] Ncbi.nlm.nih.gov. Available at: <https://www.ncbi.nlm.nih.gov/pubmed/4815813> [Accessed 3 Mar. 2019].

- [15] Kowal, D. (2014). Sculpture casting. New York: Crown Publishers, Inc., pp.24-36, 83-127, 150-188.
- [16] T. Chuter, et al., "Infrarenal aortic aneurysm structure: Implications for transfemoral repair," *Journal of Vascular Surgery*, vol. 20, no. 1, July, 1994. [doi: 10.1016/0741-5214(94)90174-0]. Available: [https://www.jvascsurg.org/article/0741-5214\(94\)90174-0/fulltext](https://www.jvascsurg.org/article/0741-5214(94)90174-0/fulltext). [Accessed Feb. 25 2019].
- [17] Karel van de Vosse, "Abdominal aortic wall thickness and compliance," University of Technology Eindhoven, Eindhoven, Netherlands, BMT Number. BMTE 08.47, Sept. 2008. Available: <http://www.mate.tue.nl/mate/pdfs/9872.pdf>. [Accessed Feb. 25, 2019].
- [18] S. Monk, *Programming Arduino: getting started with sketches*, 2nd ed., New York, NY: McGraw-Hill, 2016.
- [19] National Instruments, "What is LabVIEW," *National Instruments*, 2019. [Online]. Available: <http://www.ni.com/en-us/shop/labview.html>. [Accessed Feb. 26, 2019]
- [20] Raspberry Pi Foundation, "Getting started with GUIs," *Raspberry Pi Foundation*, [Online]. Available: <https://projects.raspberrypi.org/en/projects/getting-started-with-guis/2>. [Accessed Feb. 26, 2019]
- [21] O. Narayan, et al. "Reservoir Pressure Analysis of Aortic Blood Pressure – an in vivo study at five locations in humans," *Europe PMC Funders Group*, vol. 35, no. 10, October, 2017. [doi:10.1097/HJH.0000000000001424]. Available: <https://www.ncbi.nlm.nih.gov/pmc/articles/PMC5581543/pdf/emss-73076.pdf>. [Accessed Feb. 25, 2019].
- [22] A. V. Kamenskly, et al., "Biaxial mechanical properties of the human thoracic and abdominal aorta, common carotid, subclavian, renal and common iliac arteries," *Biomechanics and modeling in mechanobiology*, vol. 13, no. 6, November, 2014. [doi: 10.1007/s10237-014-0576-6]. Available: <https://www.ncbi.nlm.nih.gov/pubmed/24710603>. [Accessed Feb. 25, 2019]
- [23] P. J. Pritchard, J. W. Mitchell, and J. C. Leylegian, *Fox and McDonald's Introduction to Fluid Mechanics*, 9th ed., Hoboken, NJ: John Wiley & Sons, Inc., 2015
- [24] A. Rahimi and A. Mashak, Review on rubbers in medicine: Natural, silicone and polyurethane rubbers, *Plastics, Rubber and Composites*, v 42, n 6, p 223-230, July 2013.
- [25] V. Kanyanta and A. Ivankovic, "Mechanical characterisation of polyurethane elastomer for biomedical applications," *Journal of the Mechanical Behavior of Biomedical Materials*, vol. 3, no. 1, Jan., pp. 51-62, 2010.
- [26] BJB Enterprises (2019) bjbenterprises.com [Online]. Available: <https://bjbenterprises.com> [Accessed Mar. 3, 2019]
- [27] Vivitrolabs inc. (2019) vivitrolabs.com [Online]. Available: <https://vivitrolabs.com/product/endovascular-ev-simulator/>. [Accessed Feb. 1, 2019]
- [28] Vascular Simulations (2019) vascularsimulations.com [Online]. Available: <https://vascularsimulations.com/>. [Accessed Mar. 3, 2019]
- [29] Trando Med (2019) trando-med.com [Online]. Available: <https://www.trando-med.com>. [Accessed Mar. 3, 2019]
- [30] Biomedical Device Consultants & Laboratories LLC. (2019). Pulsatile Pump Systems. [online] Available at:

- <http://www.bdclabs.com/testing-equipment/pulsatile-pump-systems/> [Accessed 3 Mar. 2019].
- [31] Amazon.com. (2019). *Amazon.com: Online Shopping for Electronics, Apparel, Computers, Books, DVDs & more*. [online] Available at: [https://www.amazon.com/ref=nav logo](https://www.amazon.com/ref=nav_logo). [Accessed Feb. 28, 2019].
- [32] Pat Deegan, *Device Druid*. Devcedruid.com, 2017. [Online]. Available: <https://devicedruid.com/>. [Accessed Feb. 28, 2019]
- [33] Stratasys. (2019). “*GrabCAD*” *GrabCAD Community* [Online] Available: <https://grabcad.com/library>. [Accessed April 26 2019]
- [34] Ising, M., Sobieski, M., Slaughter, M., Koenig, S. and Giridharan, G. (2015). Feasibility of Pump Speed Modulation for Restoring Vascular Pulsatility with Rotary Blood Pumps. *ASAIO Journal*, 61(5), pp.526-532.

8 APPENDICES

8.1 Appendix A: House of Quality

Customer Requirement	Weight	Engineering Requirement	Mean Flow Rate in left iliac (ml/min)	Mean Flow Rate in right iliac (ml/min)	Aortic Pressure syst/dias (mmHg)	Hardness (shore A)	Elastic Modulus (kPa)	Wall thickness(mm)	Aneurysm Diameter (mm)	Aneurysm Length (mm)	Creep (mm/year)	See-Through Model (binary)	Fluid Temperature (C)	Weight of entire system (kg)	Total Cost (\$)	Diameter of distal Aorta (mm)	Diameter of Left iliac (mm)	Diameter of right iliac (mm)	Radius of Curvature at Right Junction (mm)	Radius of Curvature at Left Junction (mm)	Take Off Angle of Right common iliac (degrees)	Take Off Angle of Left common iliac (degrees)	Angle of iliacs in common iliac tangent plane (degrees)	Left common iliac length	Right common iliac length
1. Safe per ANSI/OSHA	10			1	3	1	1	1					1	1											
2. Easy to Move	3						1							0	1										
3. Mimic Anatomical Flow Conditions	8		8	8	8		1						1		3	8	8	8	3	3	3	3			
4. Match Aneurysm Mechanical Properties	7					8	8		8	8	8		1		3	3	3	3	3	3	3	3			
5. Match Aneurysm Geometry	8							8		8															
6. Allow Visualization of Device Deployment	8											8													
7. Replicable Manufacturing Process	8																		1	1	1	1			
8. Display Pressure	5												1		3										
9. Display Flow Rate	6												1		3										
10. Stable Base	4													3	1										
11. Display Aneurysm Volume Change	3																								
Absolute Technical Importance (ATI)																									
Relative Technical Importance (RTI)																									
Target ER values			84	111	14188	5	34.3	2.3	35	54.88	2.3	Y/N	37	11.34	2800	2188	12	12	34.57	50.5	29	14	15	58.14	60.86
Tolerances of Eris								0.8	5	4.1	0.72	n/a		11.34	200	2.84	2.15	2.84	-17.57	-26.5	7	11	5	20.01	18.88
Testing Procedure (TP#)																									

Appendix B: Engineering Drawings for CAD

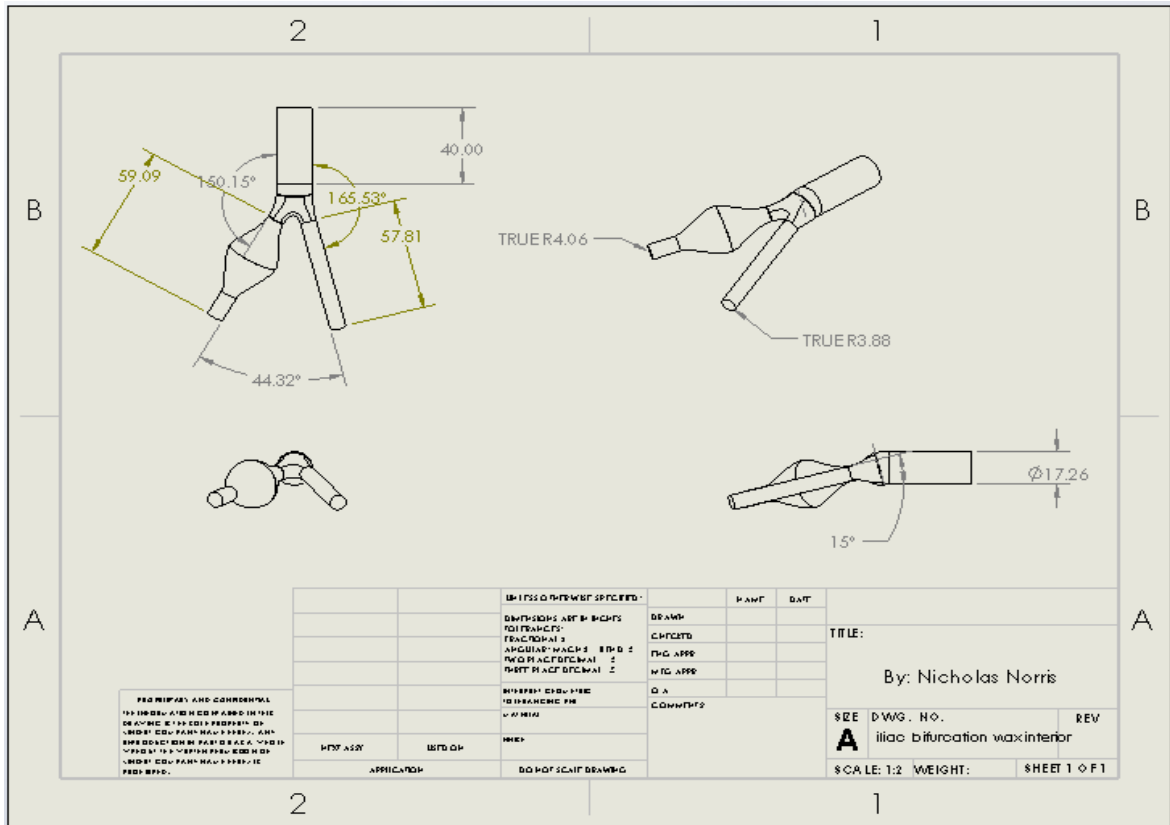

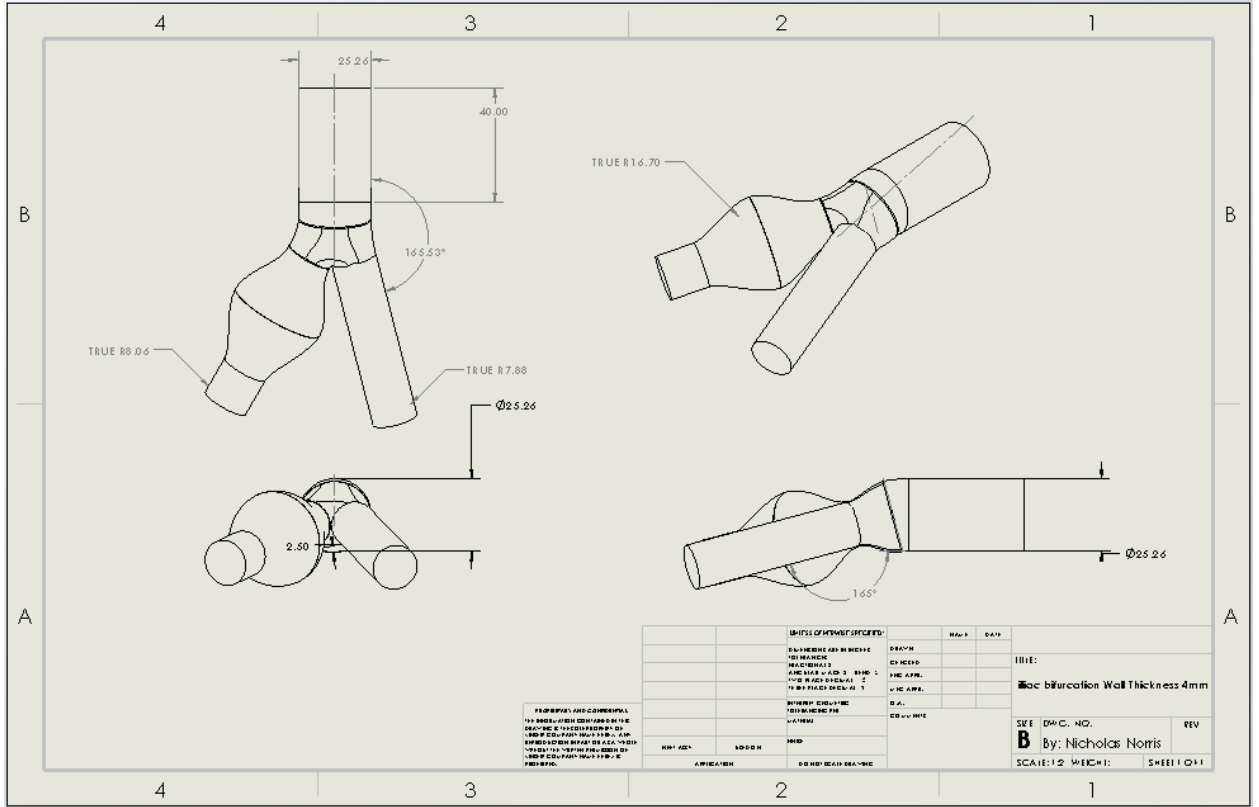

FOR THE USER AND CONTRACTOR TO BE USED AS A GUIDE ONLY. THE USER SHALL BE RESPONSIBLE FOR THE DESIGN AND CONSTRUCTION OF THE BIFURCATION. THE CONTRACTOR SHALL BE RESPONSIBLE FOR THE FABRICATION AND INSTALLATION OF THE BIFURCATION. THE CONTRACTOR SHALL BE RESPONSIBLE FOR THE TESTING AND INSPECTION OF THE BIFURCATION.

UNITS OF MEASURE SPECIFIED:		NO.	DATE
LENGTH	MILLIMETERS	01	
AREA	SQUARE MILLIMETERS	02	
VOLUME	CUBIC MILLIMETERS	03	
ANGLE	DEGREES	04	
MASS	GRAMS	05	
TEMPERATURE	DEGREES CELSIUS	06	
TIME	HOURS	07	
FORCE	NEWTONS	08	
STRESS	NEWTONS PER SQUARE MILLIMETER	09	
MODULUS OF ELASTICITY	NEWTONS PER SQUARE MILLIMETER	10	
POISSON'S RATIO		11	
COEFFICIENT OF THERMAL EXPANSION	PER DEGREE CELSIUS	12	
COEFFICIENT OF FRICTION		13	
COEFFICIENT OF RESTITUTION		14	
COEFFICIENT OF ADHESION		15	
COEFFICIENT OF SURFACE TENSION	NEWTONS PER METER	16	
COEFFICIENT OF VISCOSITY	POISE	17	
COEFFICIENT OF PERMEABILITY	DARCY	18	
COEFFICIENT OF ABSORPTION		19	
COEFFICIENT OF REFRACTION		20	
COEFFICIENT OF TRANSMISSION		21	
COEFFICIENT OF TRANSMITTANCE		22	
COEFFICIENT OF TRANSMITTANCE		23	
COEFFICIENT OF TRANSMITTANCE		24	
COEFFICIENT OF TRANSMITTANCE		25	
COEFFICIENT OF TRANSMITTANCE		26	
COEFFICIENT OF TRANSMITTANCE		27	
COEFFICIENT OF TRANSMITTANCE		28	
COEFFICIENT OF TRANSMITTANCE		29	
COEFFICIENT OF TRANSMITTANCE		30	
COEFFICIENT OF TRANSMITTANCE		31	
COEFFICIENT OF TRANSMITTANCE		32	
COEFFICIENT OF TRANSMITTANCE		33	
COEFFICIENT OF TRANSMITTANCE		34	
COEFFICIENT OF TRANSMITTANCE		35	
COEFFICIENT OF TRANSMITTANCE		36	
COEFFICIENT OF TRANSMITTANCE		37	
COEFFICIENT OF TRANSMITTANCE		38	
COEFFICIENT OF TRANSMITTANCE		39	
COEFFICIENT OF TRANSMITTANCE		40	
COEFFICIENT OF TRANSMITTANCE		41	
COEFFICIENT OF TRANSMITTANCE		42	
COEFFICIENT OF TRANSMITTANCE		43	
COEFFICIENT OF TRANSMITTANCE		44	
COEFFICIENT OF TRANSMITTANCE		45	
COEFFICIENT OF TRANSMITTANCE		46	
COEFFICIENT OF TRANSMITTANCE		47	
COEFFICIENT OF TRANSMITTANCE		48	
COEFFICIENT OF TRANSMITTANCE		49	
COEFFICIENT OF TRANSMITTANCE		50	
COEFFICIENT OF TRANSMITTANCE		51	
COEFFICIENT OF TRANSMITTANCE		52	
COEFFICIENT OF TRANSMITTANCE		53	
COEFFICIENT OF TRANSMITTANCE		54	
COEFFICIENT OF TRANSMITTANCE		55	
COEFFICIENT OF TRANSMITTANCE		56	
COEFFICIENT OF TRANSMITTANCE		57	
COEFFICIENT OF TRANSMITTANCE		58	
COEFFICIENT OF TRANSMITTANCE		59	
COEFFICIENT OF TRANSMITTANCE		60	
COEFFICIENT OF TRANSMITTANCE		61	
COEFFICIENT OF TRANSMITTANCE		62	
COEFFICIENT OF TRANSMITTANCE		63	
COEFFICIENT OF TRANSMITTANCE		64	
COEFFICIENT OF TRANSMITTANCE		65	
COEFFICIENT OF TRANSMITTANCE		66	
COEFFICIENT OF TRANSMITTANCE		67	
COEFFICIENT OF TRANSMITTANCE		68	
COEFFICIENT OF TRANSMITTANCE		69	
COEFFICIENT OF TRANSMITTANCE		70	
COEFFICIENT OF TRANSMITTANCE		71	
COEFFICIENT OF TRANSMITTANCE		72	
COEFFICIENT OF TRANSMITTANCE		73	
COEFFICIENT OF TRANSMITTANCE		74	
COEFFICIENT OF TRANSMITTANCE		75	
COEFFICIENT OF TRANSMITTANCE		76	
COEFFICIENT OF TRANSMITTANCE		77	
COEFFICIENT OF TRANSMITTANCE		78	
COEFFICIENT OF TRANSMITTANCE		79	
COEFFICIENT OF TRANSMITTANCE		80	
COEFFICIENT OF TRANSMITTANCE		81	
COEFFICIENT OF TRANSMITTANCE		82	
COEFFICIENT OF TRANSMITTANCE		83	
COEFFICIENT OF TRANSMITTANCE		84	
COEFFICIENT OF TRANSMITTANCE		85	
COEFFICIENT OF TRANSMITTANCE		86	
COEFFICIENT OF TRANSMITTANCE		87	
COEFFICIENT OF TRANSMITTANCE		88	
COEFFICIENT OF TRANSMITTANCE		89	
COEFFICIENT OF TRANSMITTANCE		90	
COEFFICIENT OF TRANSMITTANCE		91	
COEFFICIENT OF TRANSMITTANCE		92	
COEFFICIENT OF TRANSMITTANCE		93	
COEFFICIENT OF TRANSMITTANCE		94	
COEFFICIENT OF TRANSMITTANCE		95	
COEFFICIENT OF TRANSMITTANCE		96	
COEFFICIENT OF TRANSMITTANCE		97	
COEFFICIENT OF TRANSMITTANCE		98	
COEFFICIENT OF TRANSMITTANCE		99	
COEFFICIENT OF TRANSMITTANCE		100	

DATE: 10/10/2020
 TIME: 10:00 AM
 Bifurcation Wall Thickness: 4mm
 SHEET DWG. NO. **B** By: Nicholas Norris
 SCALE: 1:2 WHICH: SHEET 1 OF 1

Appendix C: Bill of Materials and Budget

Budget for Gore Capstone Thus Far				
		Budget	\$3,000	
Items Purchased and Received	Items Purchased but Not Received	Expected Purchases	Cost	Rational and Comments
Arduino UNO R3			\$35.00	Arduino for GUI
Silicone Tubing			\$0.00	Donated from Client
		Aquarium Pump	\$12.50	Prototyping
		3D printing	\$15.00	prototyping
Polyurethane samples			\$0.00	Donated for testing from a manufacturer
		Flow Sensor	\$30.00	GUI or some visual reading
		Pressure Sensor	\$50.00	GUI or Pressure Gauge (relatively same price)
TC-5041 A/B (1 Gallon)			\$120.30	For making the wax core mold and vascular mold
WC-540 A/B (1 Quart)			\$75.00	For making casts of the vasculature
Mold Making Kit			\$118.00	Complete kit with everything needed to create molds
SC-22 (1 Quart)			\$44.00	Polyurethane thinner to lower shore hardness
Lumbar			\$20.00	to make mold boxes
		Vacuum Pump	\$170.00	Degassing Silicone and Poly
		Mold release	\$15.00	to release polyurethane from molds
		Mixing cups	\$40.00	for manufacturing
		Modeling Clay (sulfur free)	\$8.00	Modeling clay will be used in casting.
		Wax	\$13.00	For Lost Wax Casting
		Final Pump	\$60.00	could be piston pump. Price can vary
		Frame for Model	\$10.00	3D Print
		Sturdy Cart	\$80.00	This will hold the entire system.
		3 gallon container	\$20.00	This will hold liquid for the system.
		Time on Rheometer	\$150.00	Testing samples of polyurethane and silicone
		3D printing	\$40.00	For aneurysm model and base to hold model.
		Shipping	\$100.00	In case shipping is expensive
		Poster	\$100.00	For the most shiney poster
Cost			\$1,325.80	
Current Budget Remaining for Unknown Expense			\$1,674.20	

Appendix D: Manufacturing Process

Step 1

Cut Plexiglas into appropriate lengths to form mold box.

2 – 130.36mm x 55mm (long side)

2 – 109mm x 55mm (short side)

1 – 132mm x 109mm (base)

Step 2

Coat your 3D print in your release agent and let dry

Step 3

Prepare liquid volume for silicone.

Take part A and measure 376 ml in measuring cup, then with a new cup add 38 ml of part B. Use new cup to pour part A and B into new cup mix for 2 min. vacuum the air out of the liquid.

Step 4

Press clay into bottom of casting box with a 15 Degree plate and Take your 3D print and slowly press print into clay until half of the print is submerged. pour the 414 ml into acrylic box. Let cure overnight.

Step 5

Remove clay and cut out alignment keys for your next pour in a location that will not affect the 3D print. Place pour and vent bodies on the print. Coat silicone surface in release agent and let dry.

Step 6

Repeat step 3 and pour silicone into box from an edge and let silicone cover the part. Do not directly pour silicone on the part and let cure overnight.

Step 7

Repeat Steps 1-6 for the inner core.

Step 8

Remove cores from molds and place molds together. Cut pour holes in top of each iliac leg (one will vent and the other will fill)

Step 9

Melt 23ml of wax in a pan on low heat. Take inner mold and pour hot wax into mold until wax is level with surface of silicone. Let cure for 1 hour and remove wax from mold

Step 10

Place wax into outer mold align discs or narrowing points. Close mold and pour 35 ml material into fill hole until level with silicone. Let cure overnight.

Step 11

Place mold on a plate that can accommodate 35 ml of fluid space the silicone up off the plate so the wax can drip out. Place plate in front of small heater until wax melts out. Rotate the mold every few minutes in order to heat evenly. Once all wax melts out let cool and remove bifurcation. Trim off any access with an Exacto Knife and repeat steps 1 – 11 until thirteen bifurcations have been achieved